

7- Quantum Simulation

گام های بزرگ در علوم

یا

در شیوه های مطالعه علوم

هندسه قدیمی

هندسه تحلیلی

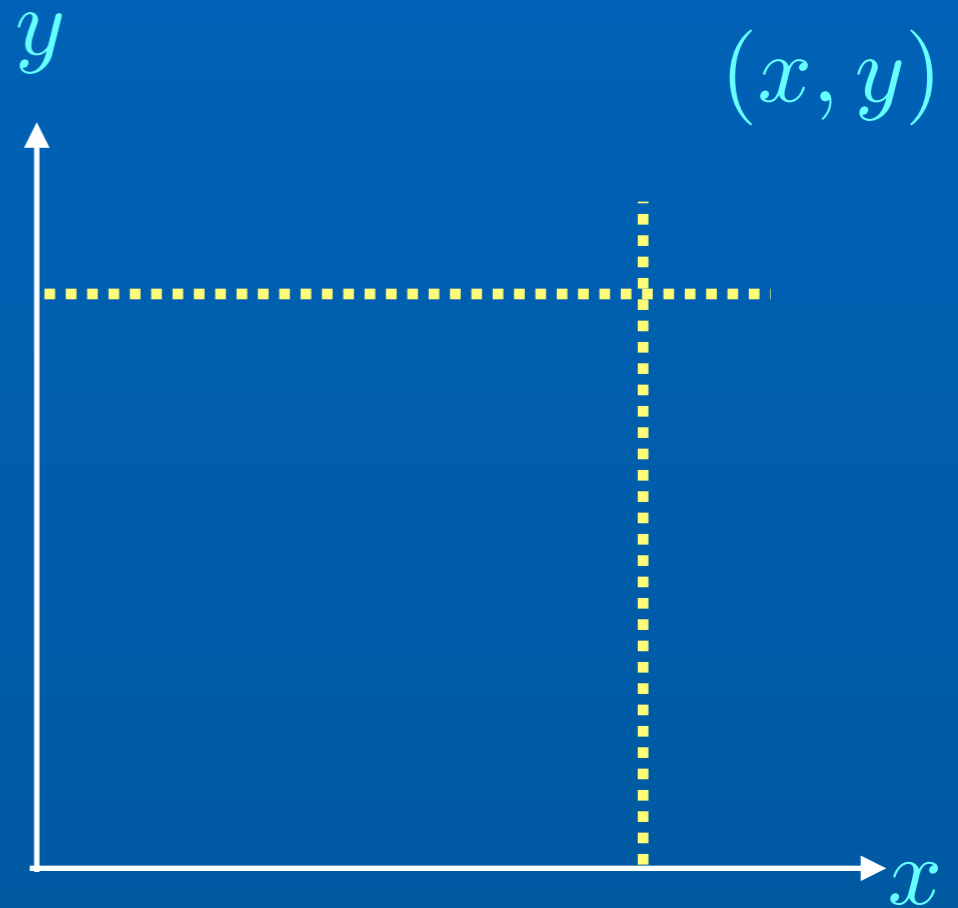
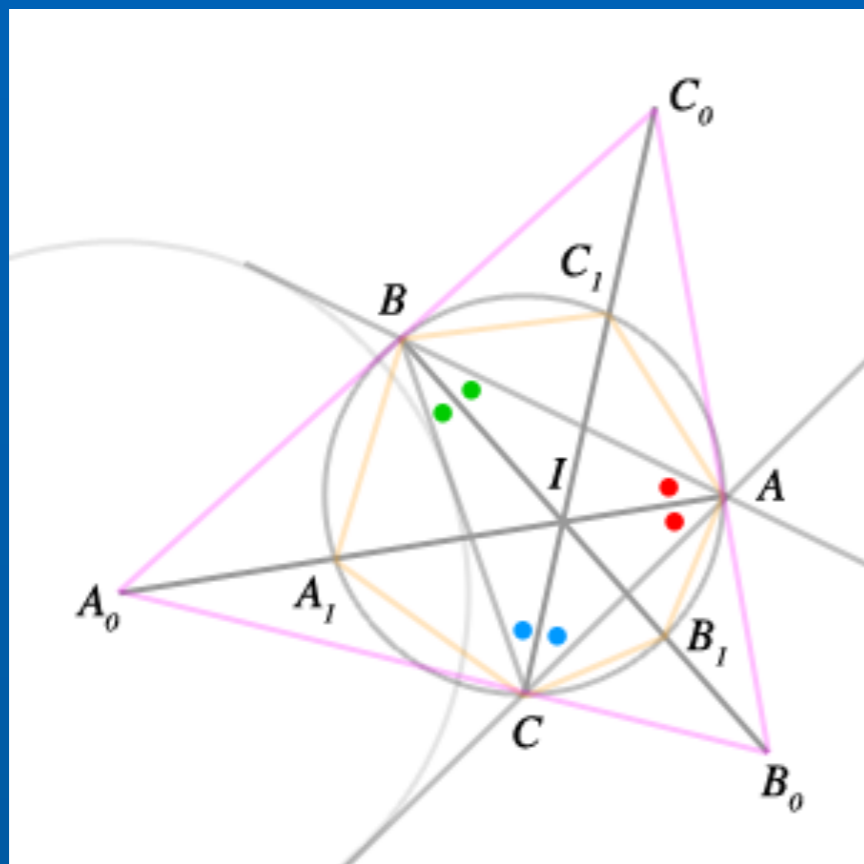

خلاقیت

محاسبات جبری



حل های تحلیلی

$$\begin{aligned}\ddot{\mathbf{r}}_1 &= -Gm_2 \frac{\mathbf{r}_1 - \mathbf{r}_2}{|\mathbf{r}_1 - \mathbf{r}_2|^3} - Gm_3 \frac{\mathbf{r}_1 - \mathbf{r}_3}{|\mathbf{r}_1 - \mathbf{r}_3|^3}, \\ \ddot{\mathbf{r}}_2 &= -Gm_3 \frac{\mathbf{r}_2 - \mathbf{r}_3}{|\mathbf{r}_2 - \mathbf{r}_3|^3} - Gm_1 \frac{\mathbf{r}_2 - \mathbf{r}_1}{|\mathbf{r}_2 - \mathbf{r}_1|^3}, \\ \ddot{\mathbf{r}}_3 &= -Gm_1 \frac{\mathbf{r}_3 - \mathbf{r}_1}{|\mathbf{r}_3 - \mathbf{r}_1|^3} - Gm_2 \frac{\mathbf{r}_3 - \mathbf{r}_2}{|\mathbf{r}_3 - \mathbf{r}_2|^3}.\end{aligned}$$

حل های عددی و شبیه سازی عددی

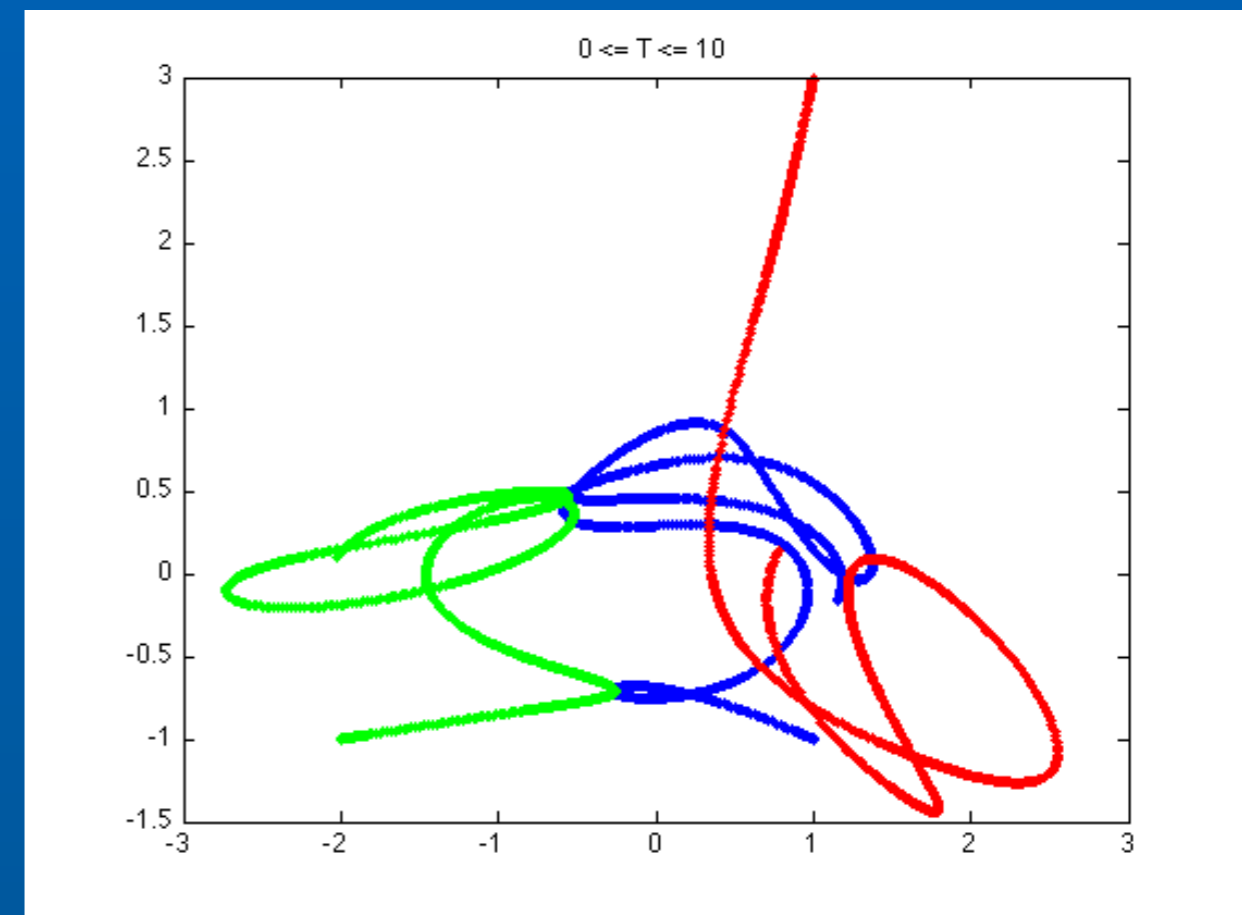

شبیه سازی منظومه شمس

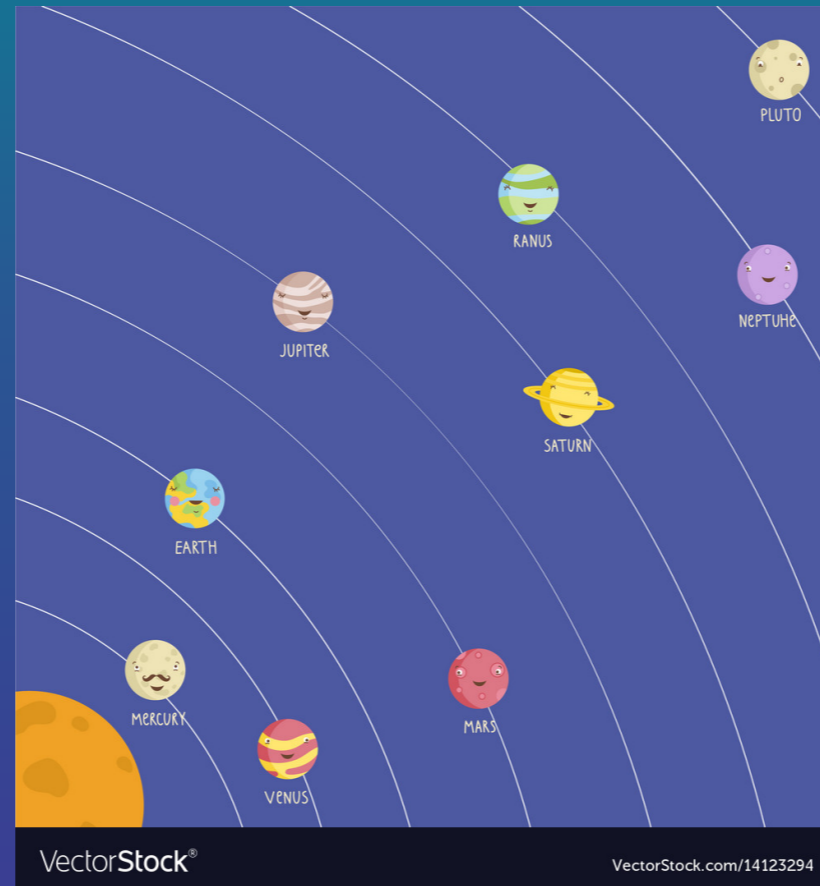

تعداد متغیرها

$$6 \times N$$

$$\frac{d}{dt}x_i = f_i(x_1, \dots, x_{6N})$$

شبیه سازی یک خوشه ستاره ای

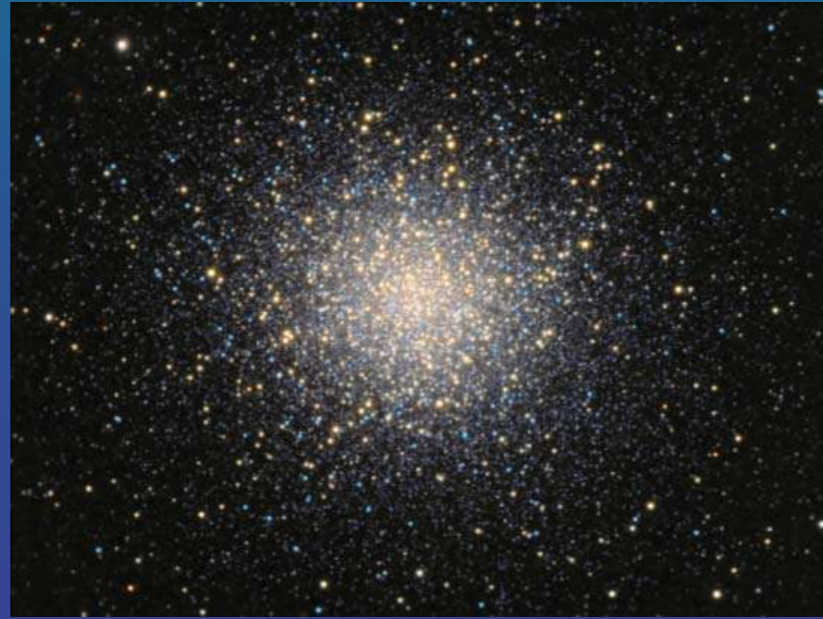

تعداد متغیرها $6 \times N$

$$\frac{d}{dt}x_i = f_i(x_1, \dots, x_{6N})$$

شبیه سازی در مهندسی

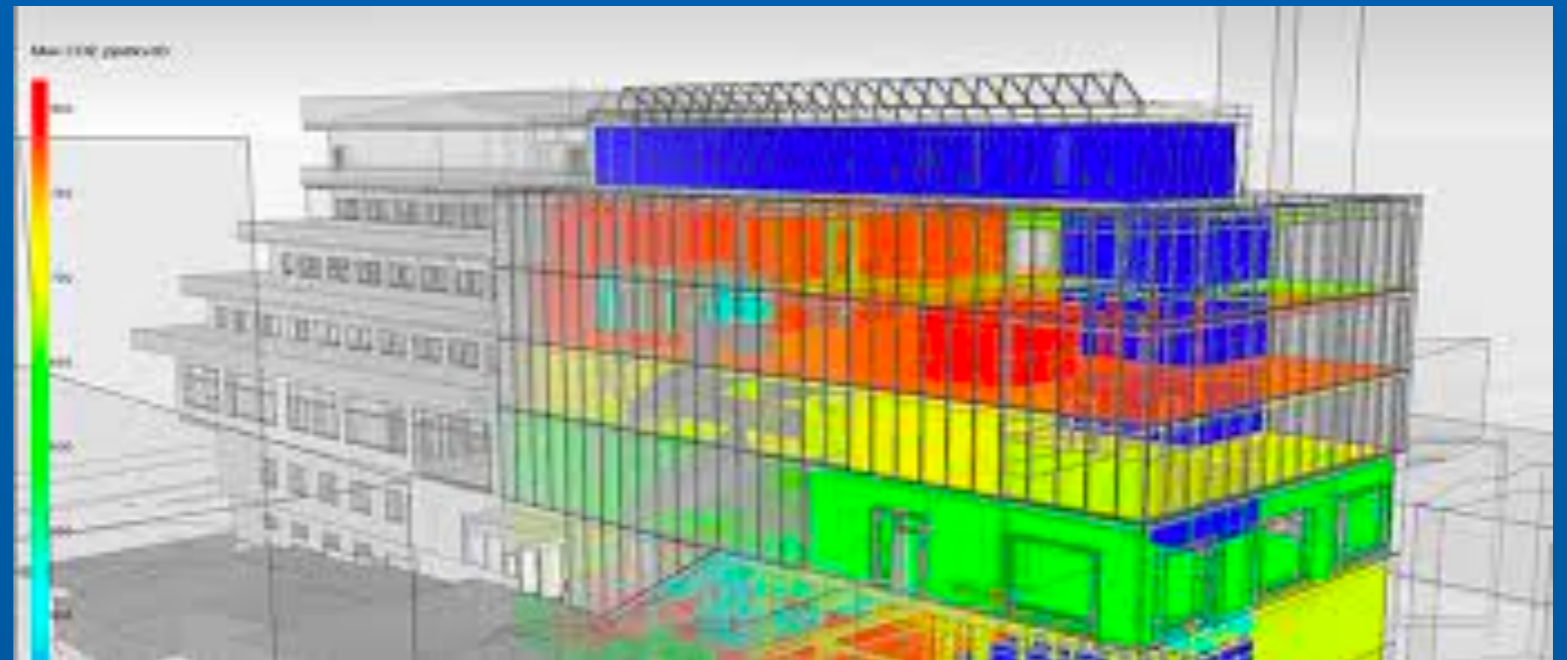
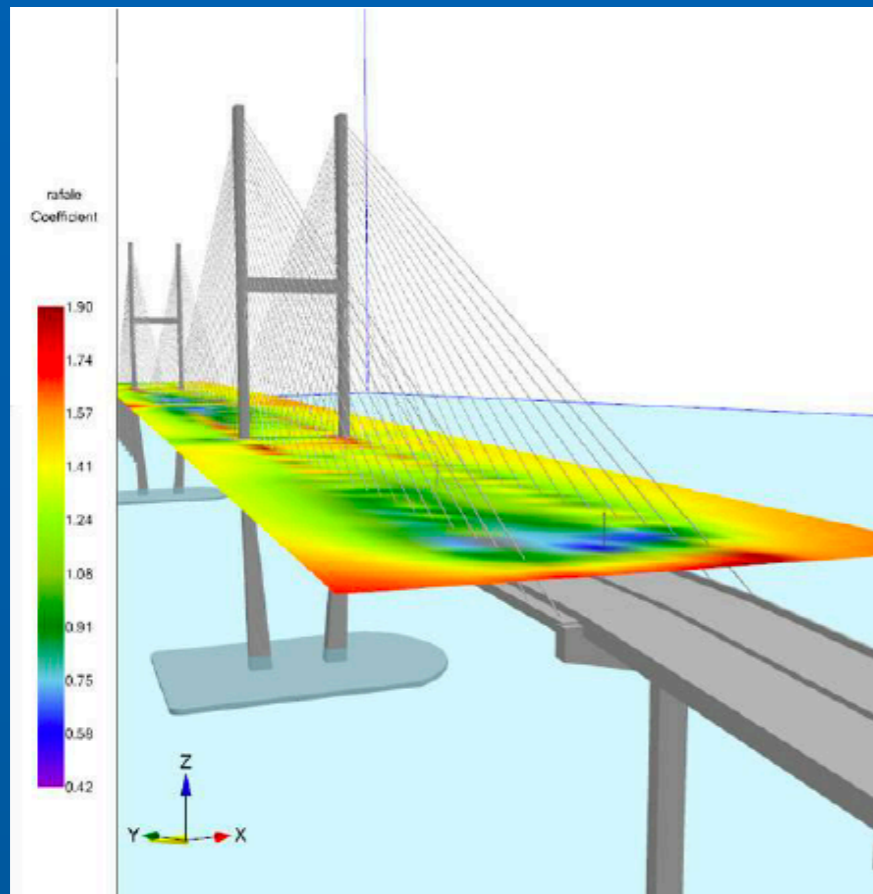

شبیه سازی محدود در شیمی و بیوشیمی

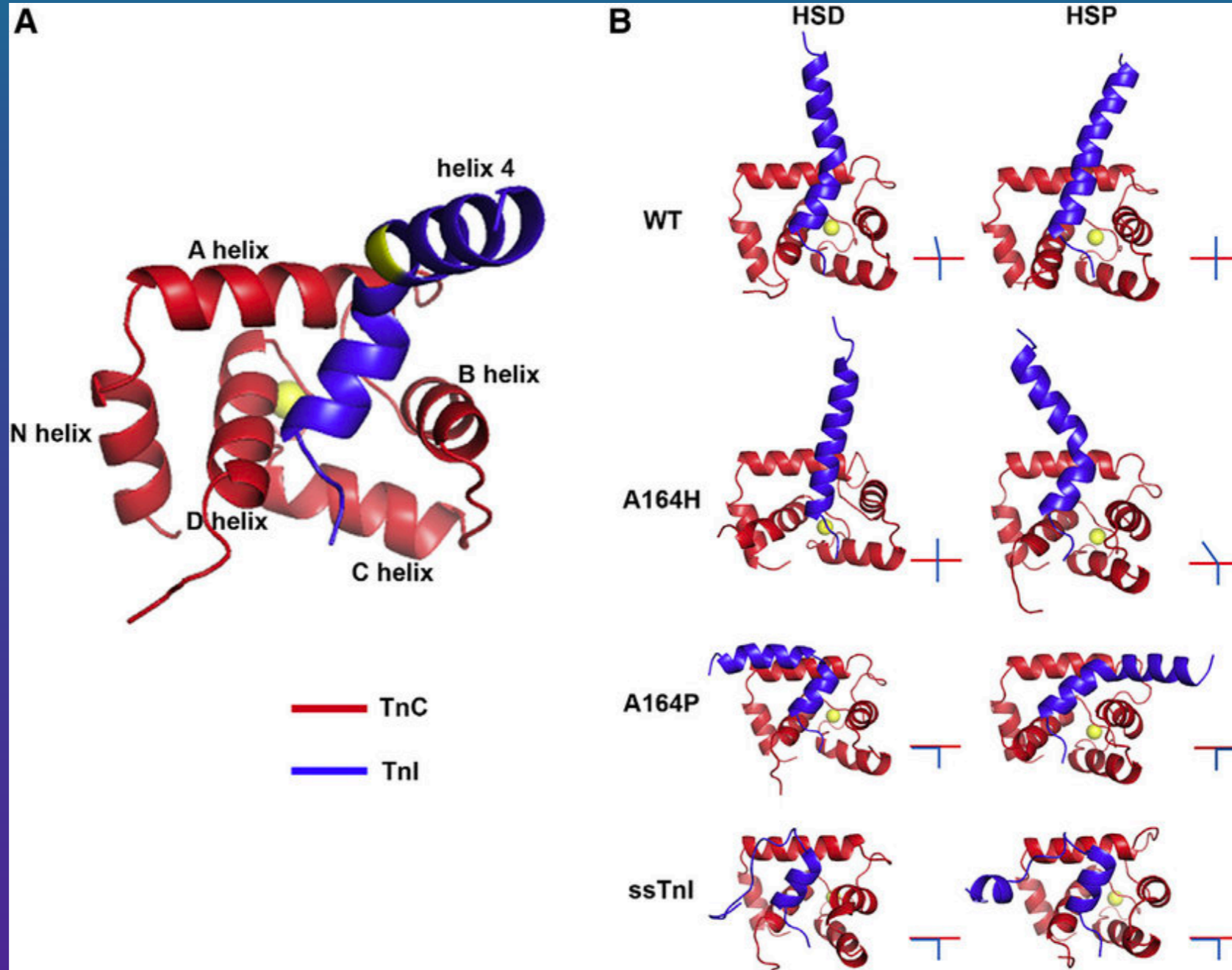

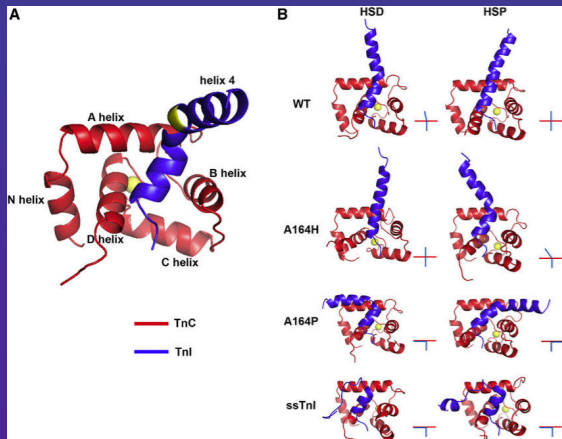
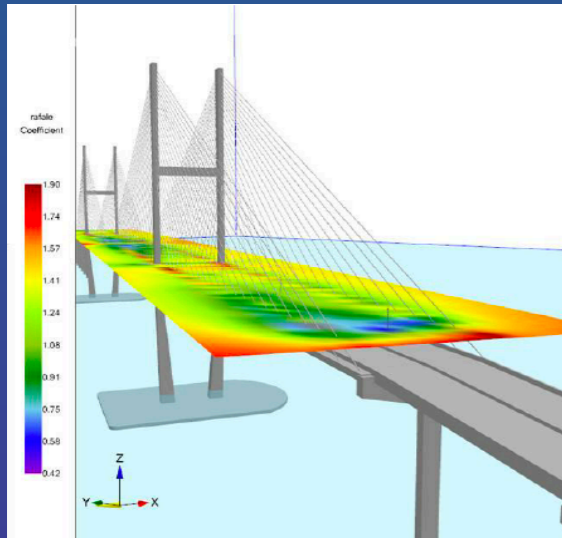

Classical Simulator

مسائل آسان

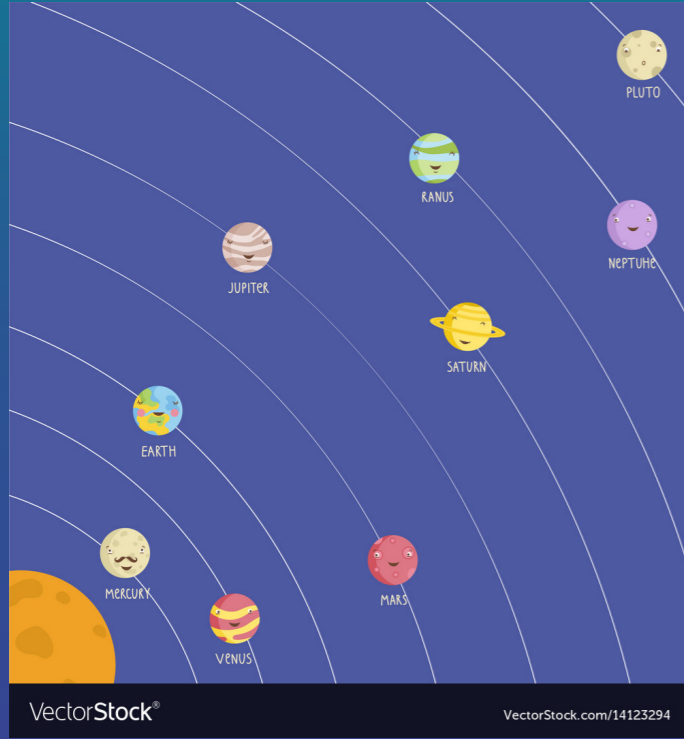

حافظه مورد نیاز

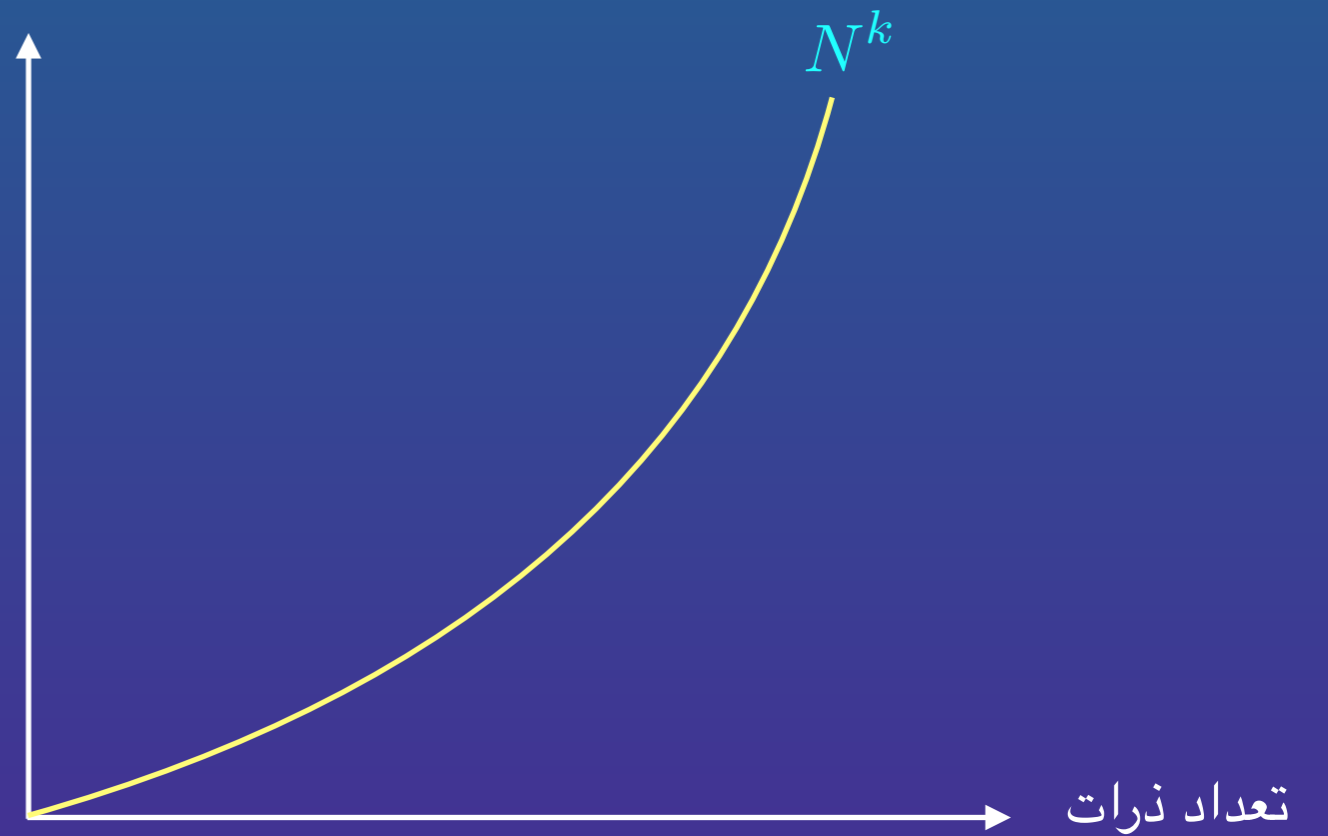

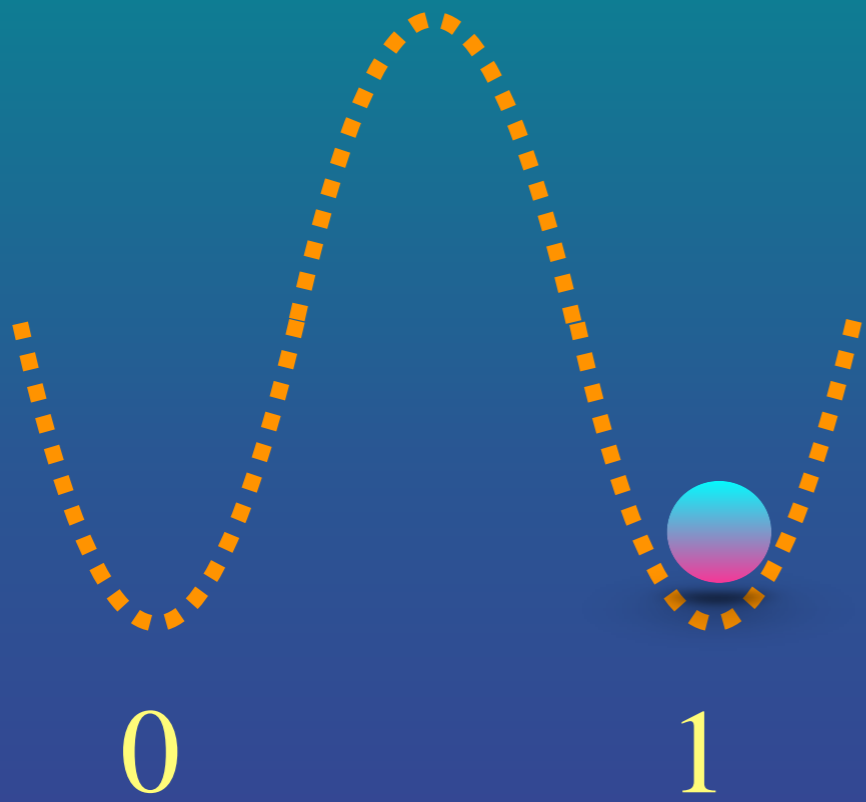

$$|\psi\rangle = a|0\rangle + b|1\rangle$$

$a \longrightarrow$ 0101010001011011

$b \longrightarrow$ 1011010010110101



$$\dim(H) = 2^N$$

$$|\Psi\rangle = a_1 |1\rangle + a_2 |2\rangle + \cdots a_{2^N} |2^N\rangle$$

$$2^{10} = 1024 \text{ Bytes}$$

$$2^{100} \approx 10^{24} \text{ Giga Bytes}$$

حتی یک سیستم ساده

کوانتومی را نیز نمی توانیم در یک کامپیوتر کلاسیک شبیه سازی کنیم.

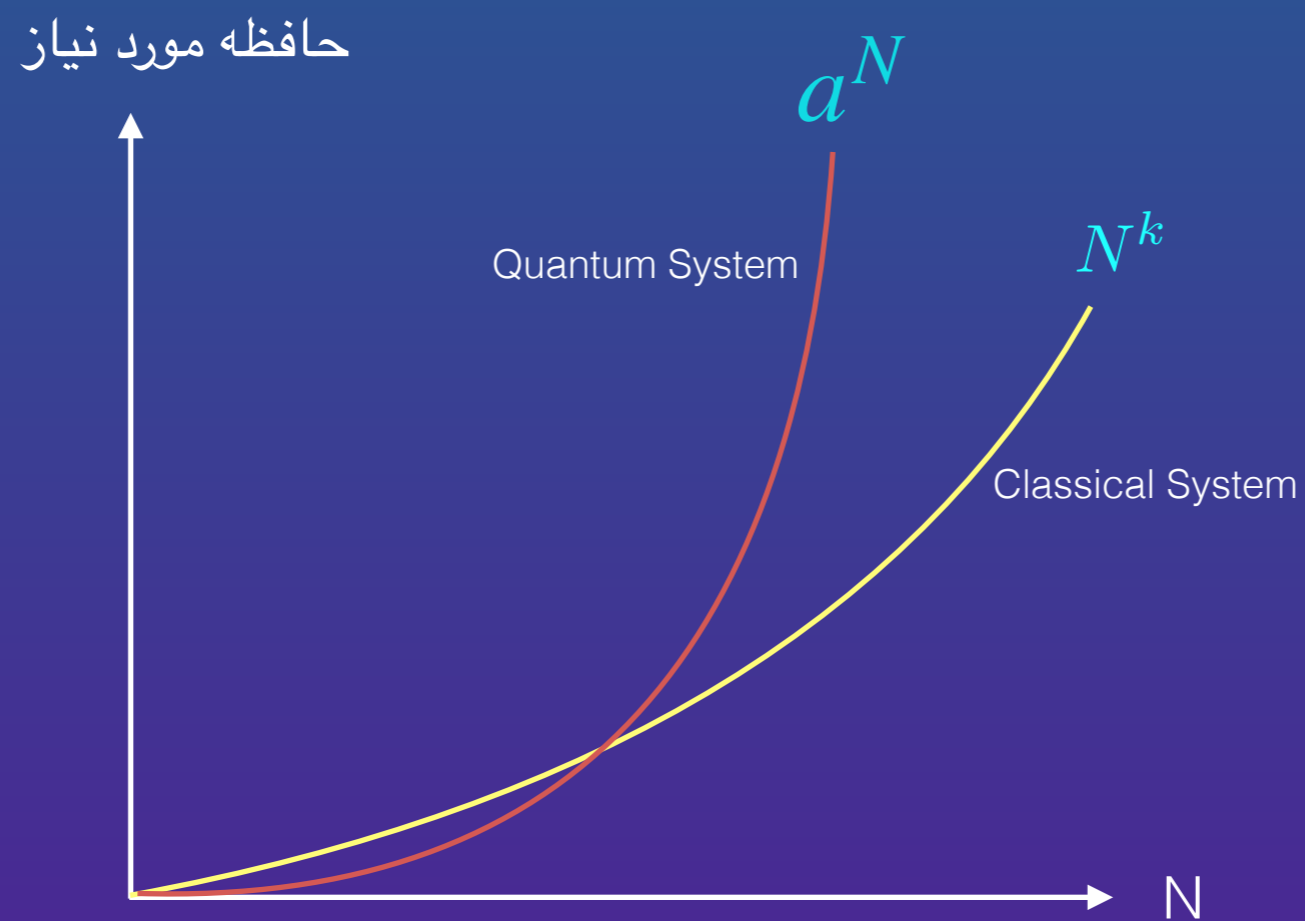

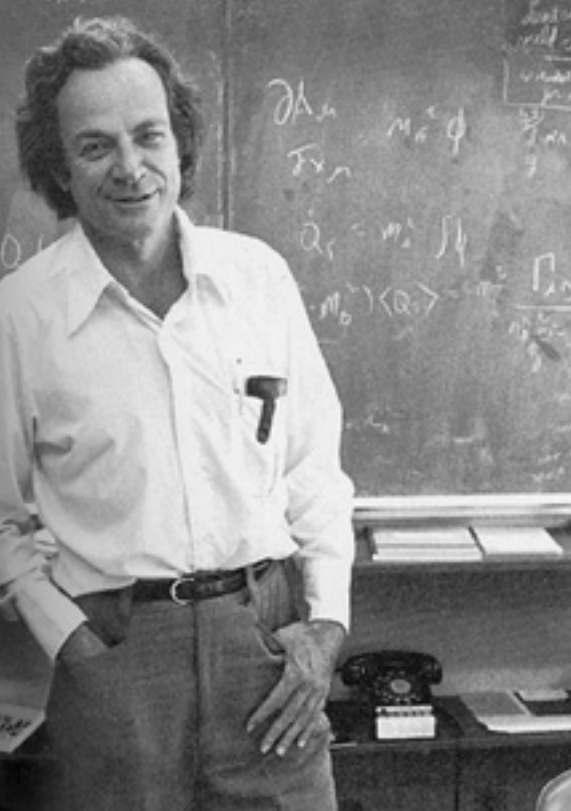

شبیه سازی کوانتومی

استفاده از یک سیستم کوانتومی ساده برای
شبیه سازی یک سیستم کوانتومی دیگر



$$i \frac{d}{dt} |\psi\rangle = H |\psi(t)\rangle$$

A-Digital Quantum Simulation

A1-Dynamics of a particle in one dimension

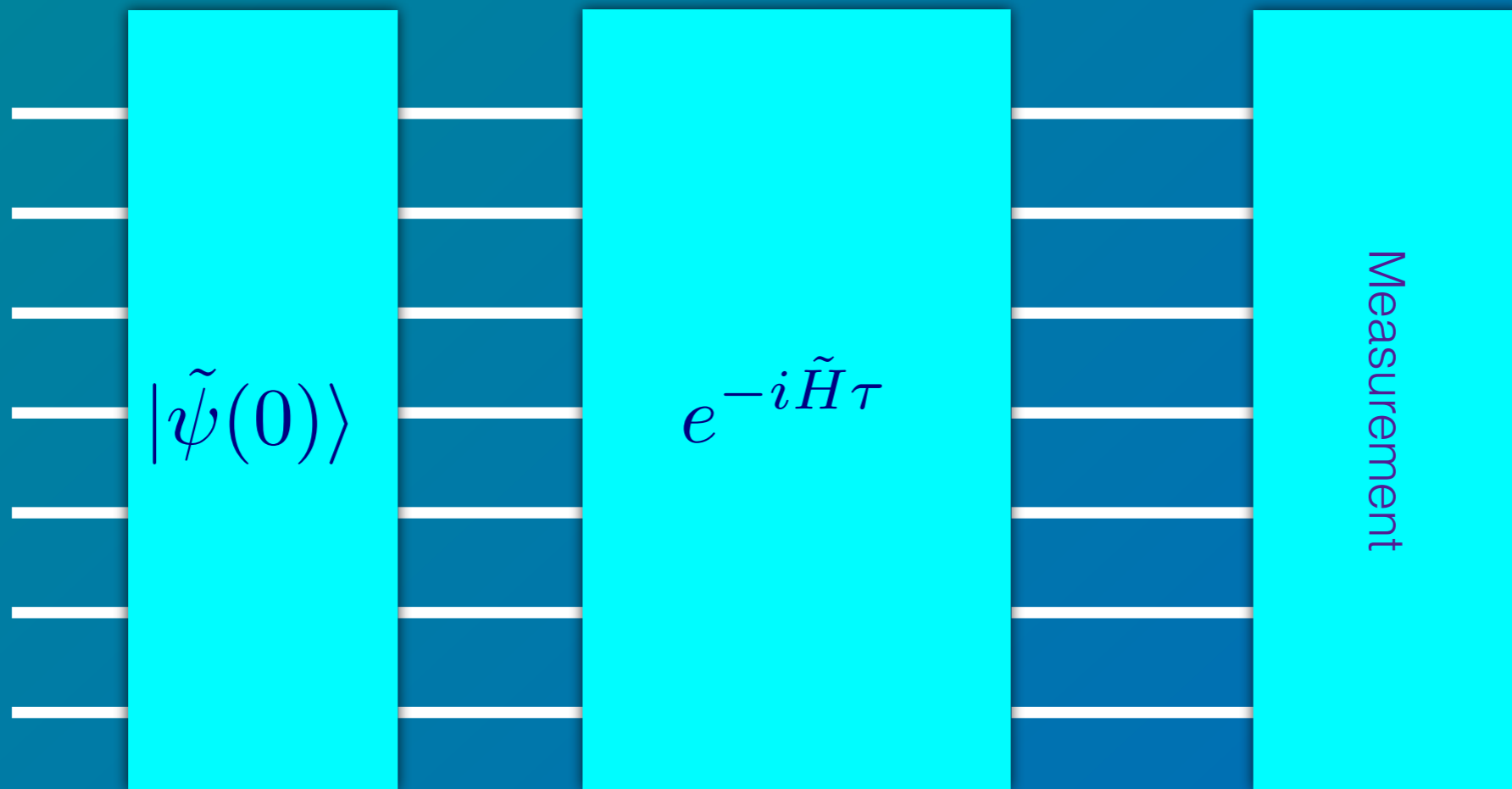

$$|\tilde{\psi}\rangle = e^{-i\tilde{H}\tau} |\tilde{\psi}(0)\rangle$$

یک مثال خیلی ساده

Simulation of the dynamics of a single particle

$$i \frac{d}{dt} |\psi\rangle = H |\psi(t)\rangle$$

Efficient Simulation of Quantum Systems by Quantum Computers

Christoff Zalka

Preparation of the initial state

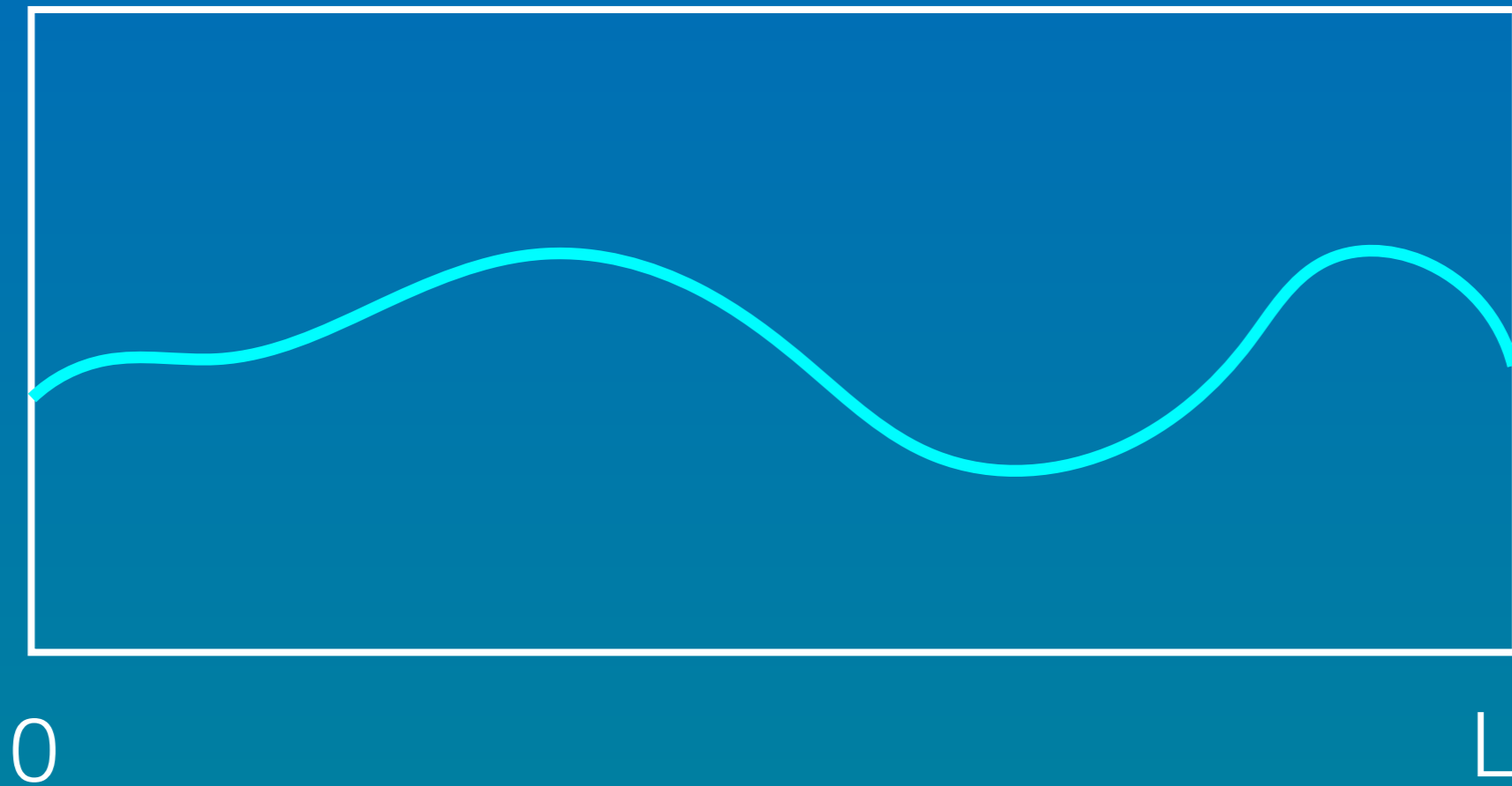

$$|\psi\rangle = \int_0^L \psi(x) |x\rangle$$

If we have only one qubit, we approximate the wave function as follows

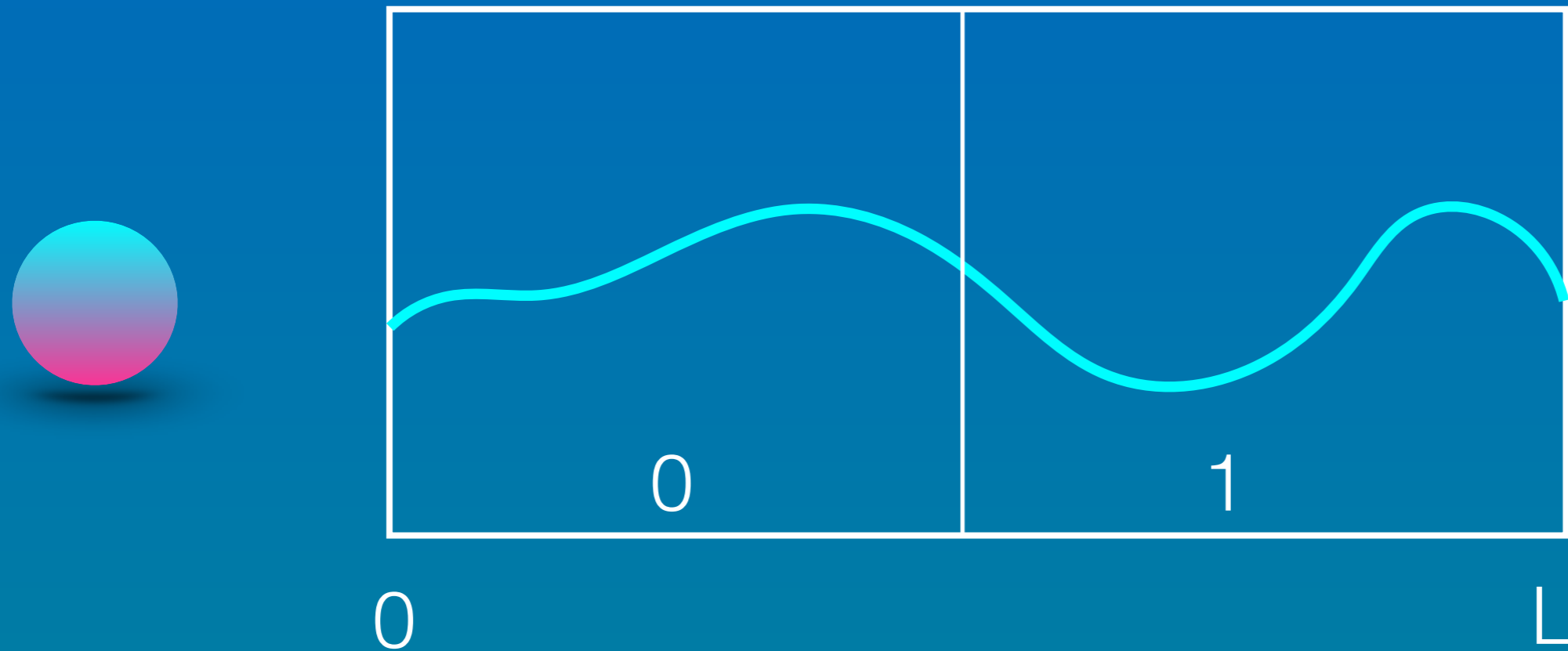

$$|\psi\rangle = \cos \phi |0\rangle + \sin \phi |1\rangle$$

$$\cos^2 \phi = \int_0^{\frac{L}{2}} |\psi(x)|^2 dx$$

$$\sin^2 \phi = \int_{\frac{L}{2}}^L |\psi(x)|^2 dx$$

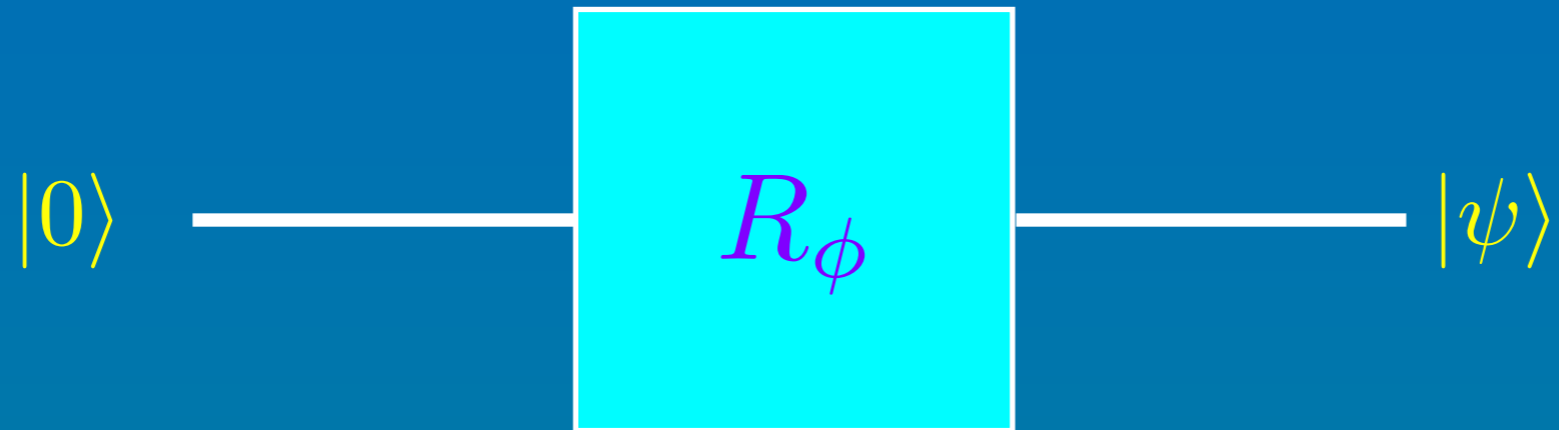

$$\begin{pmatrix} 1 \\ 0 \end{pmatrix} R_\phi = \begin{pmatrix} \cos \phi & -\sin \phi \\ \sin \phi & \cos \phi \end{pmatrix} \begin{pmatrix} \cos \phi \\ \sin \phi \end{pmatrix}$$

If we have only two qubits, we can do a better approximation

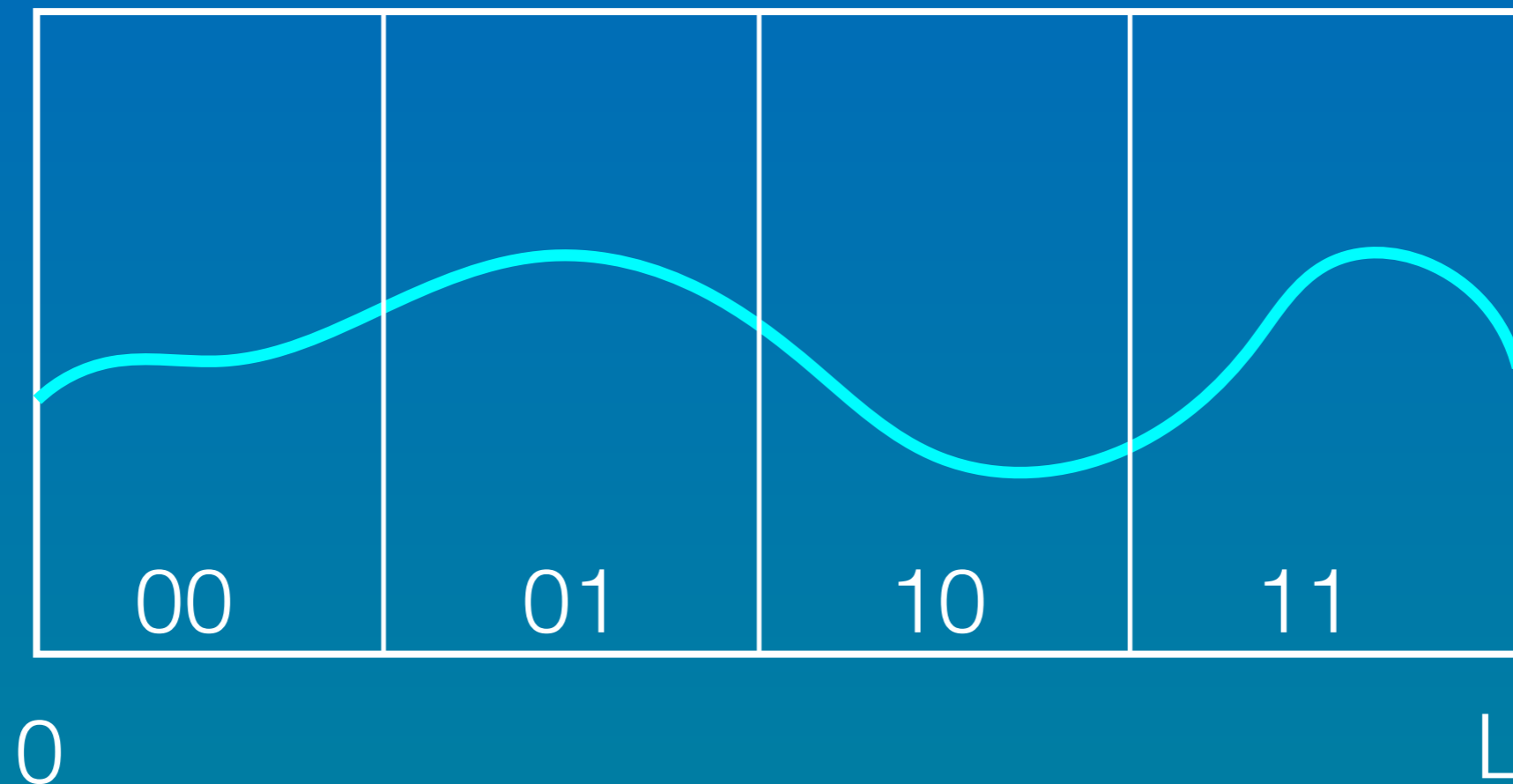
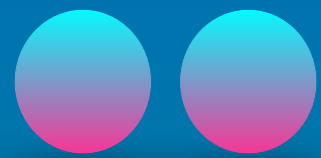

$$|\psi\rangle = a|00\rangle + b|01\rangle + c|10\rangle + d|11\rangle$$

$$a_n = \psi(n\Delta) \quad |\psi\rangle = \sum_{n=0}^{N-1} a_n |n\rangle, \quad N = 2^{\text{number of bins}}$$

Assuming that a , b , c , and d are real, we can choose the three rotation angles to produce the state.

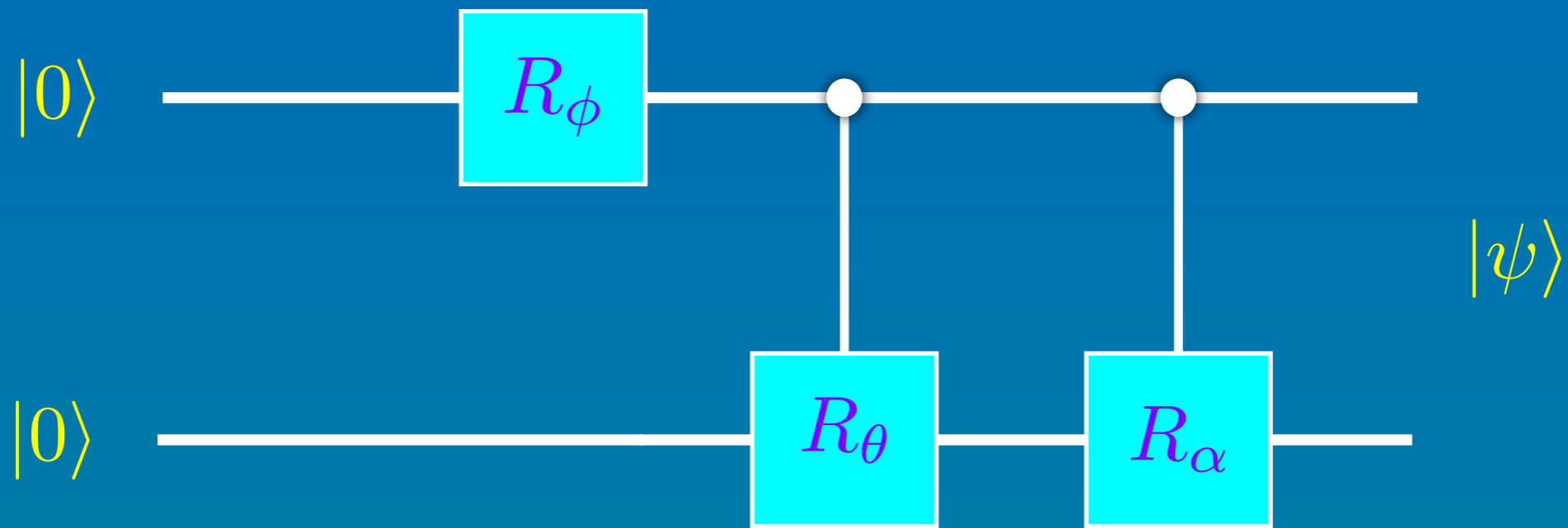

$$|\psi\rangle = a|00\rangle + b|01\rangle + c|10\rangle + d|11\rangle$$

With 3 qubits, we can have 8 bins.

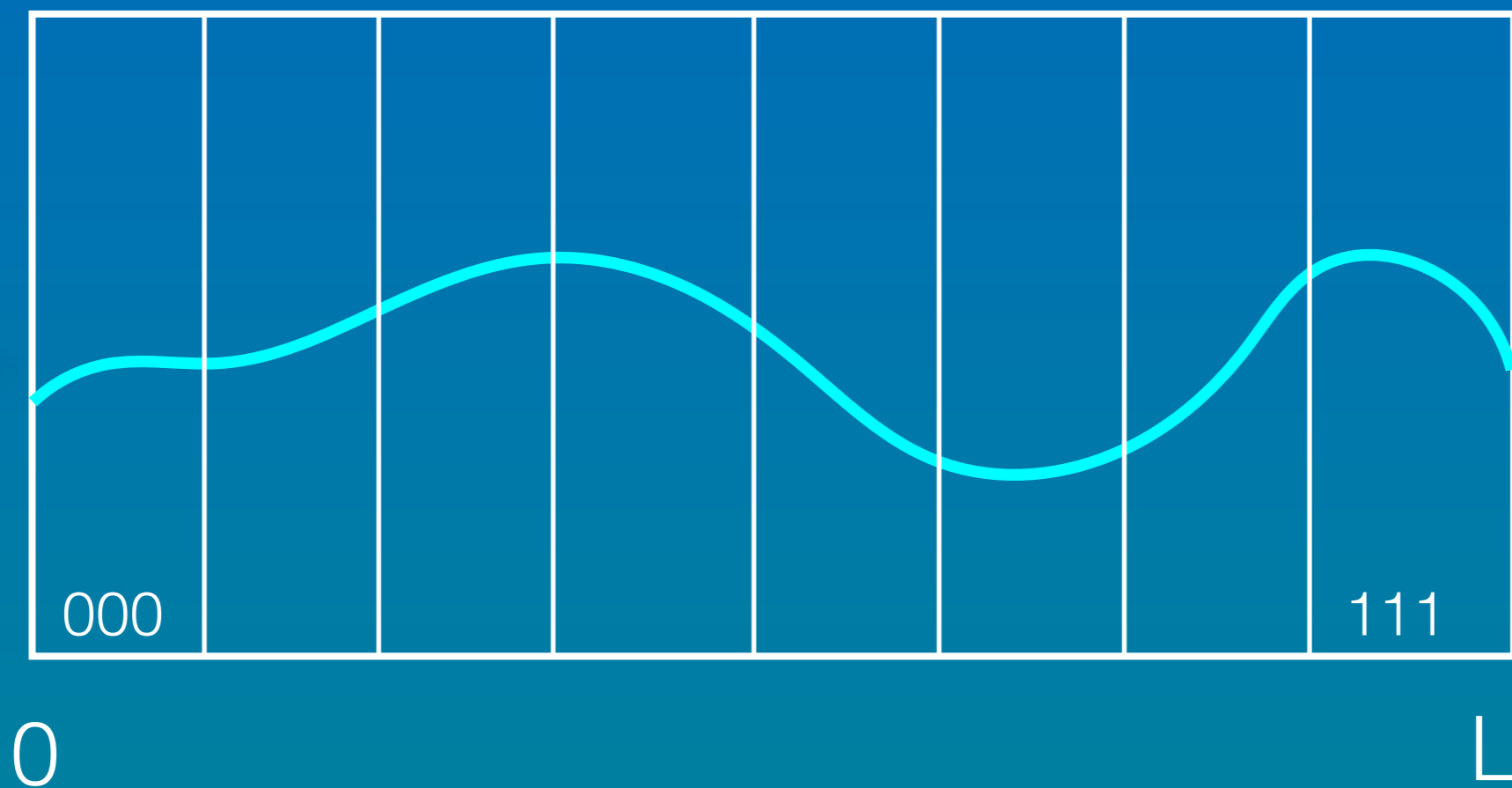
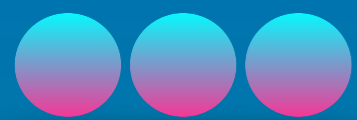

With 3 qubits

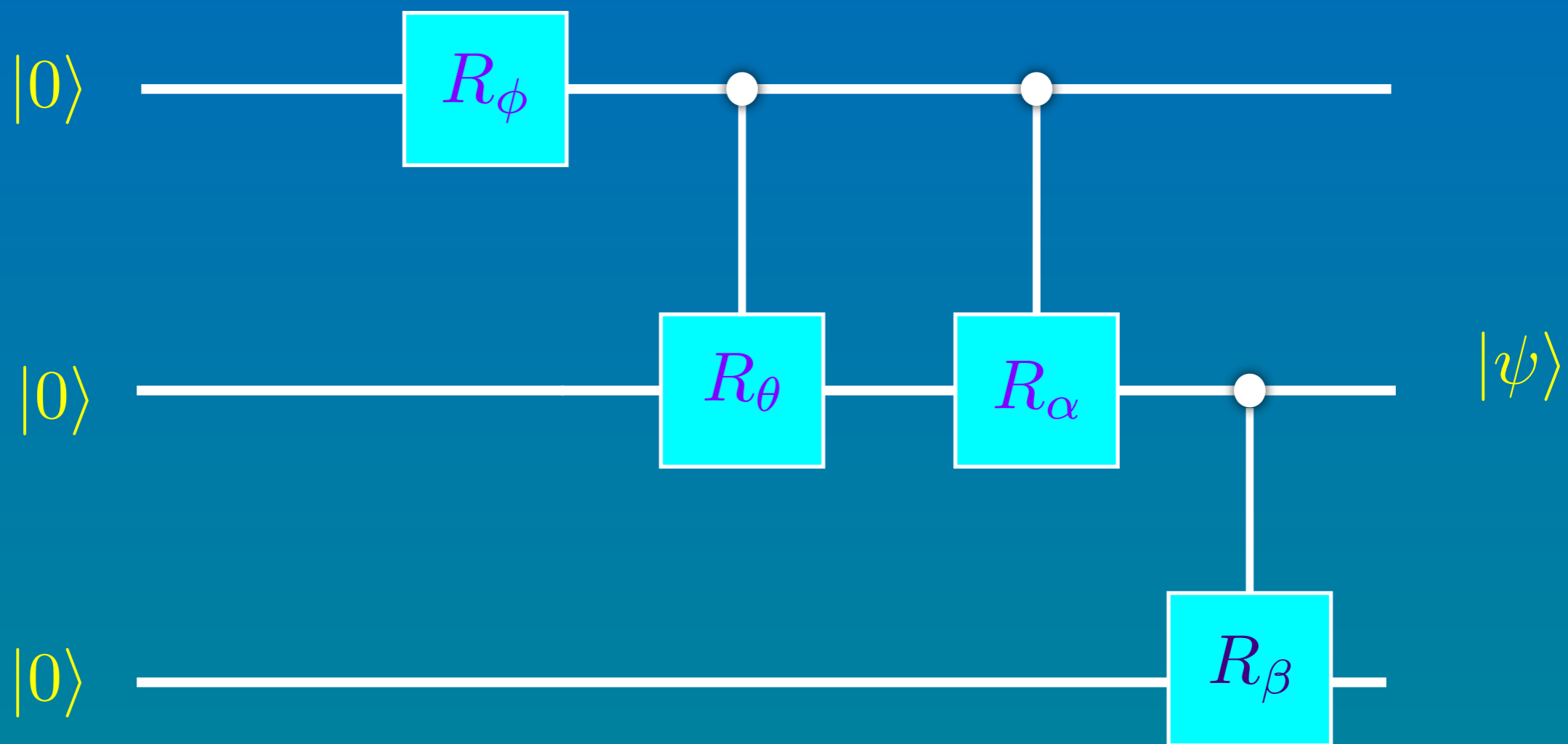

With 20 qubits, we can have 1 million bins.

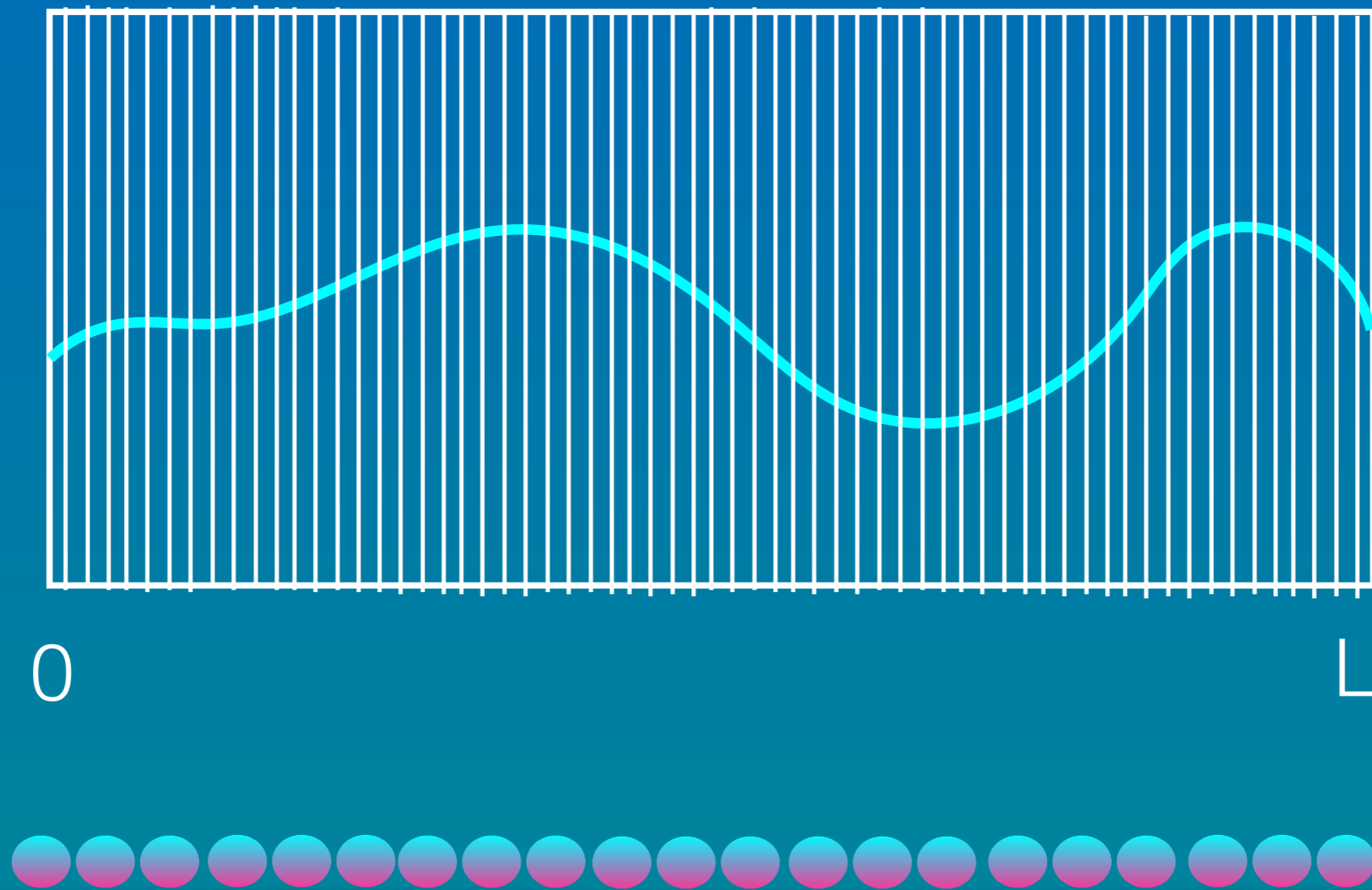

$$2^{20} = 1048576 \approx 1,000,000$$

Dynamics

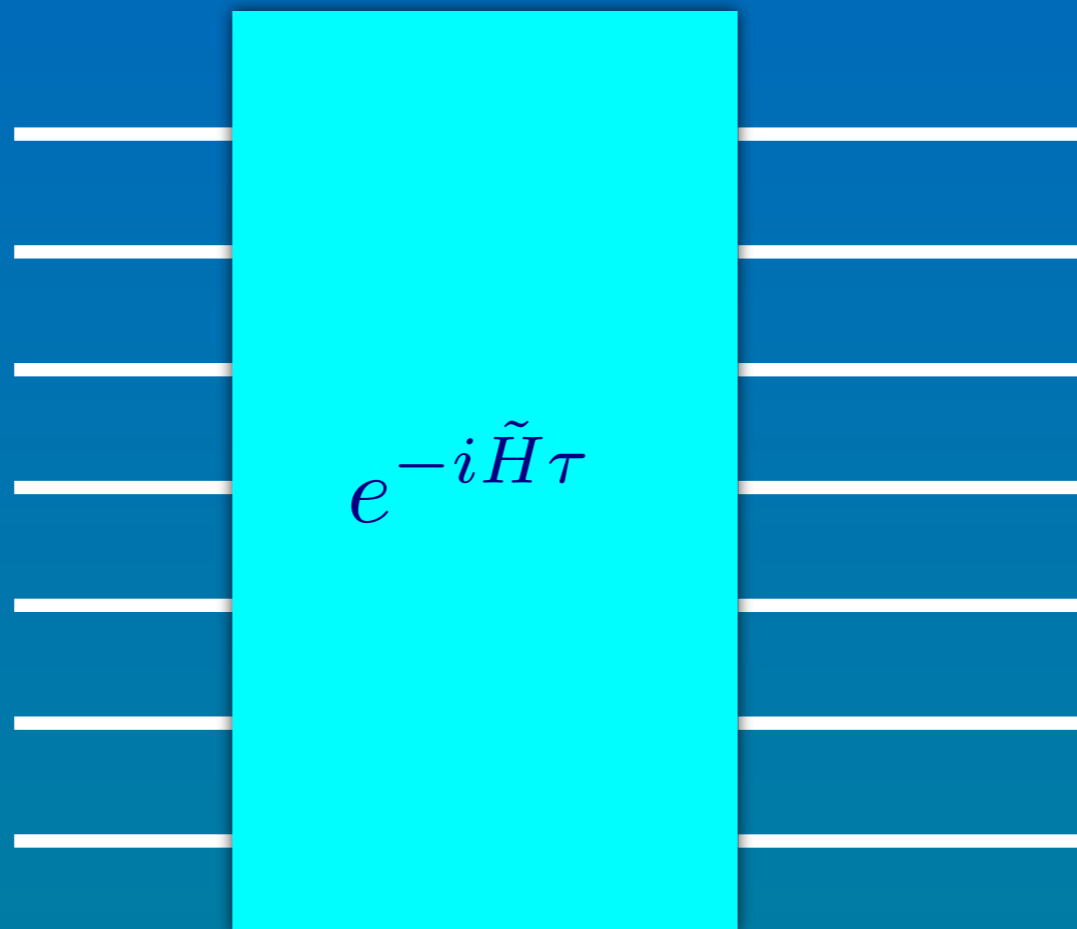

$$G(x_1, x_2, t) = ke^{i\frac{m}{2}\frac{(x_1 - x_2)^2}{\tau} - iV(x_1)\tau}$$

$$G(n_1, n_2, t) = \frac{1}{\sqrt{N}} e^{i\frac{m}{2}\frac{(n_1 - n_2)^2\Delta^2}{\tau} - iV(n_1\Delta)\tau}$$

$$G(n_1, n_2, t) = \frac{1}{\sqrt{N}} e^{-i\frac{m}{2} \frac{n^2 \Delta^2}{\tau} + iV(n\Delta)\tau} \times \sum_{n'=0}^{N-1} e^{im \frac{nn' \Delta^2}{\tau}} \times e^{-im \frac{n'^2 \Delta^2}{\tau}}$$

↑
↑
↑
Diagonal
Fourier transform
Diagonal

But for one single particle or for a few particles,
we do not need quantum simulators.

The real power of quantum simulators, becomes apparent,
when we have many particles.

Efficient Simulation of Quantum Systems by Quantum Computers

Christoff Zalka

Universal Quantum Simulators

Seth Lloyd

Expectation Values

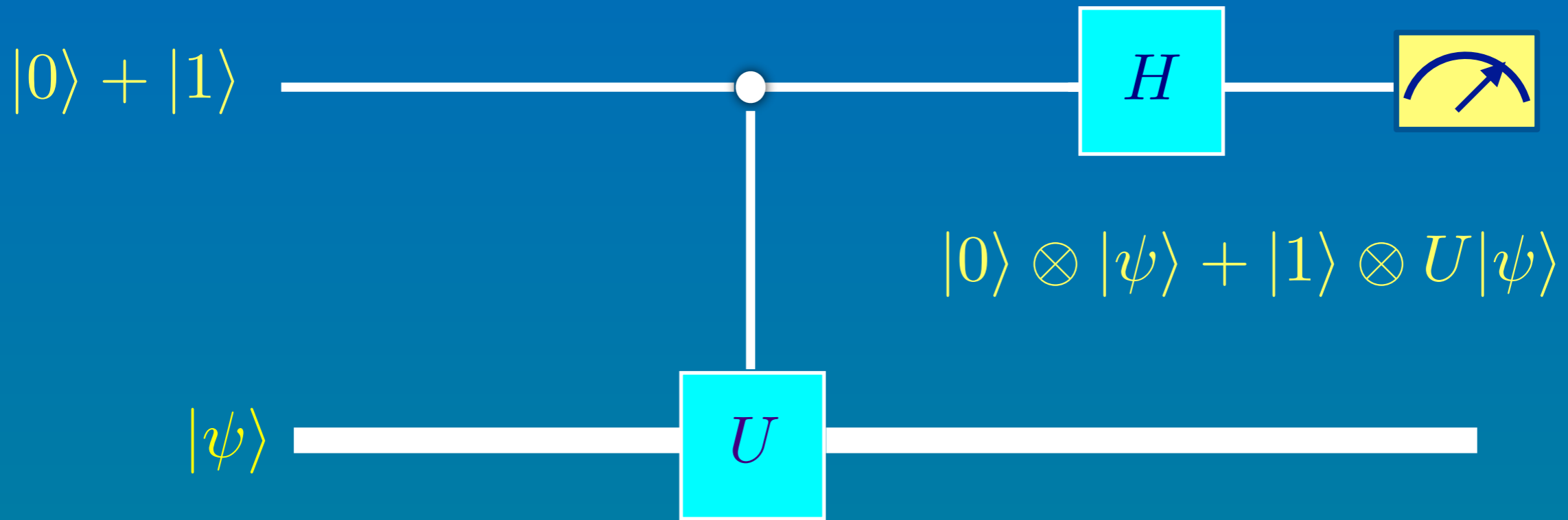

$$P(0) = \frac{1}{4} \|(I + U)|\psi\rangle\|^2$$

$$P(0) = \frac{1}{2} (1 + \text{Re}\langle\psi|U|\psi\rangle)$$

$$P(1) = \frac{1}{4} \|(I - U)|\psi\rangle\|^2$$

$$P(1) = \frac{1}{2} (1 - \text{Re}\langle\psi|U|\psi\rangle)$$

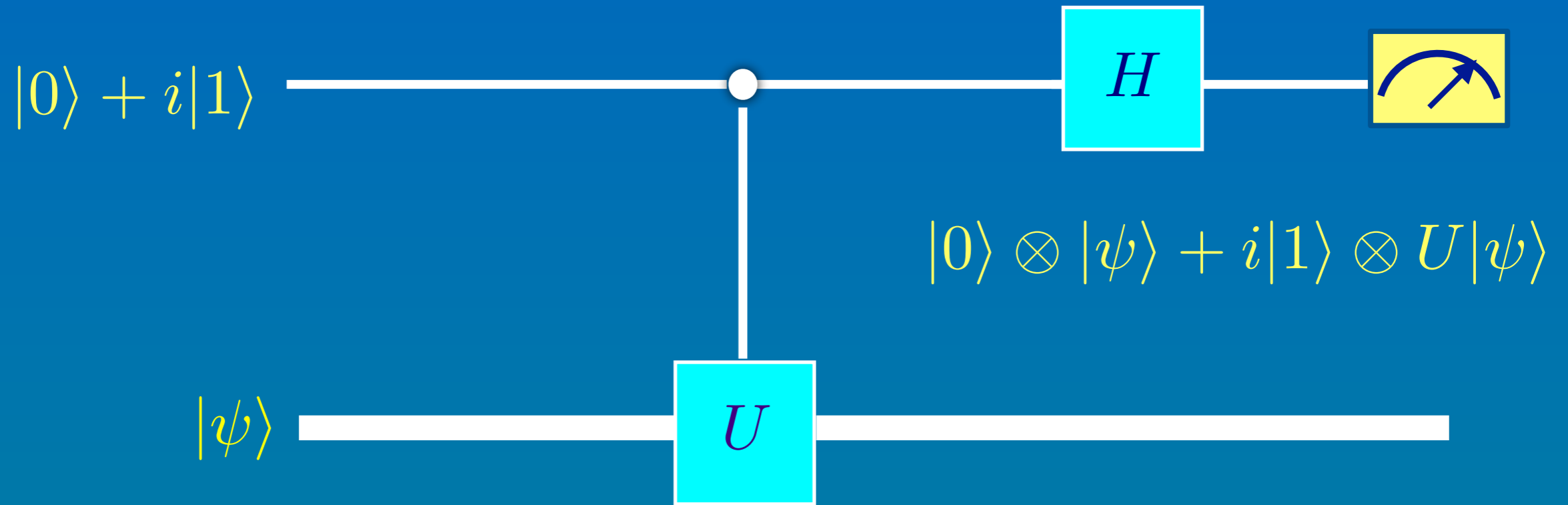

$$P(0) = \frac{1}{4} \|(I + iU)|\psi\rangle\|^2$$

$$P(0) = \frac{1}{2} (1 - \text{Im}\langle\psi|U|\psi\rangle)$$

$$P(1) = \frac{1}{4} \|(I - iU)|\psi\rangle\|^2$$

$$P(1) = \frac{1}{2} (1 + \text{Im}\langle\psi|U|\psi\rangle)$$

Finding the spectrum of a Hamiltonian

$$U = e^{iH}$$



$$H|\psi_m\rangle = E_m|\psi_m\rangle$$

$$U|\psi_m\rangle = e^{iE_m}|\psi_m\rangle$$

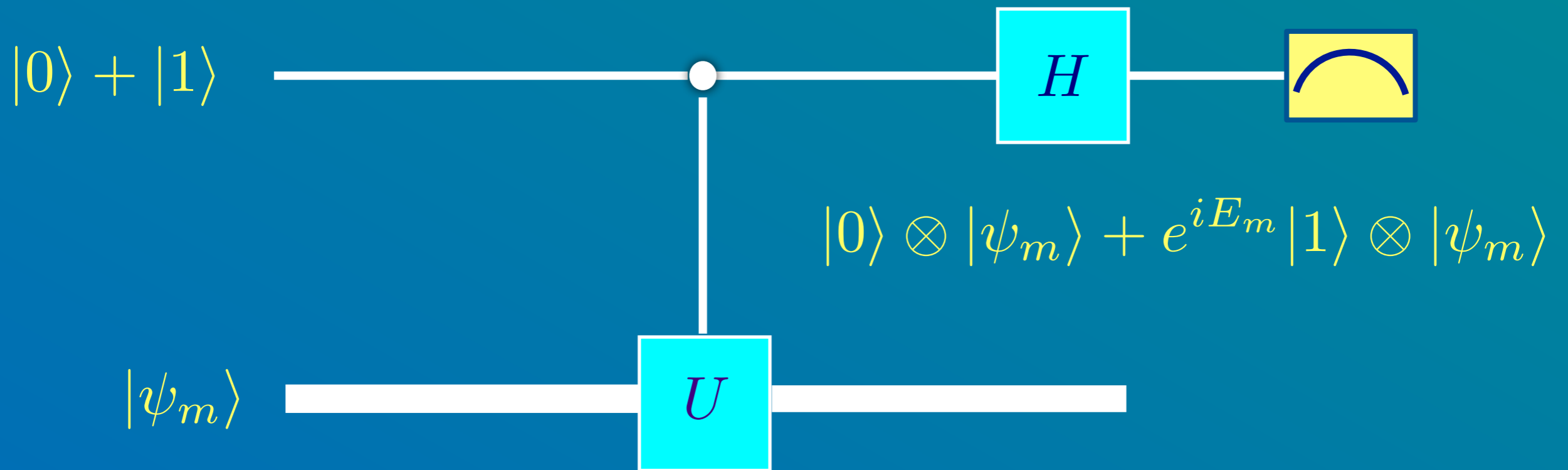

$$P(0) = \frac{1}{2}(1 + \cos E_m)$$

$$P(1) = \frac{1}{2}(1 - \cos E_m)$$

$$\frac{1}{\sqrt{N}} \sum_{k=0}^{N-1} |k\rangle$$

$$\sum_m \alpha_m |\psi_m\rangle$$

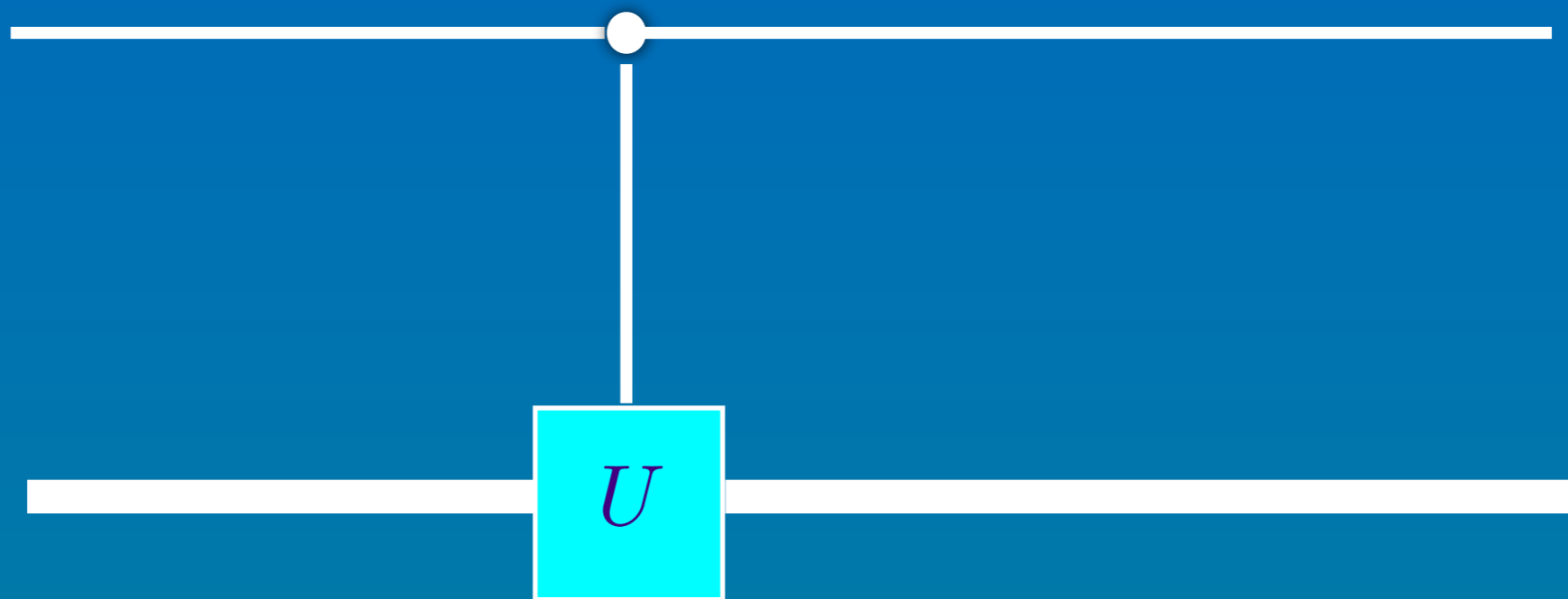

$$\sum_{m,k} \alpha_m |k\rangle \otimes U^k |\psi_m\rangle$$

$$\frac{1}{\sqrt{N}} \sum_{k,m} \alpha_m |k\rangle \otimes e^{ikE_m} |\psi_m\rangle$$

$$\frac{1}{\sqrt{N}} \sum_{k,m} \alpha_m |k\rangle \otimes e^{ikE_m} |\psi_m\rangle$$

=

$$\frac{1}{\sqrt{N}} \sum_m \alpha_m \left(\sum_k e^{ikE_m} |k\rangle \right) \otimes |\psi_m\rangle$$

$$\frac{1}{\sqrt{N}} \sum_m \alpha_m \left(\sum_k e^{ikE_m} |k\rangle \right) \otimes |\psi_m\rangle$$

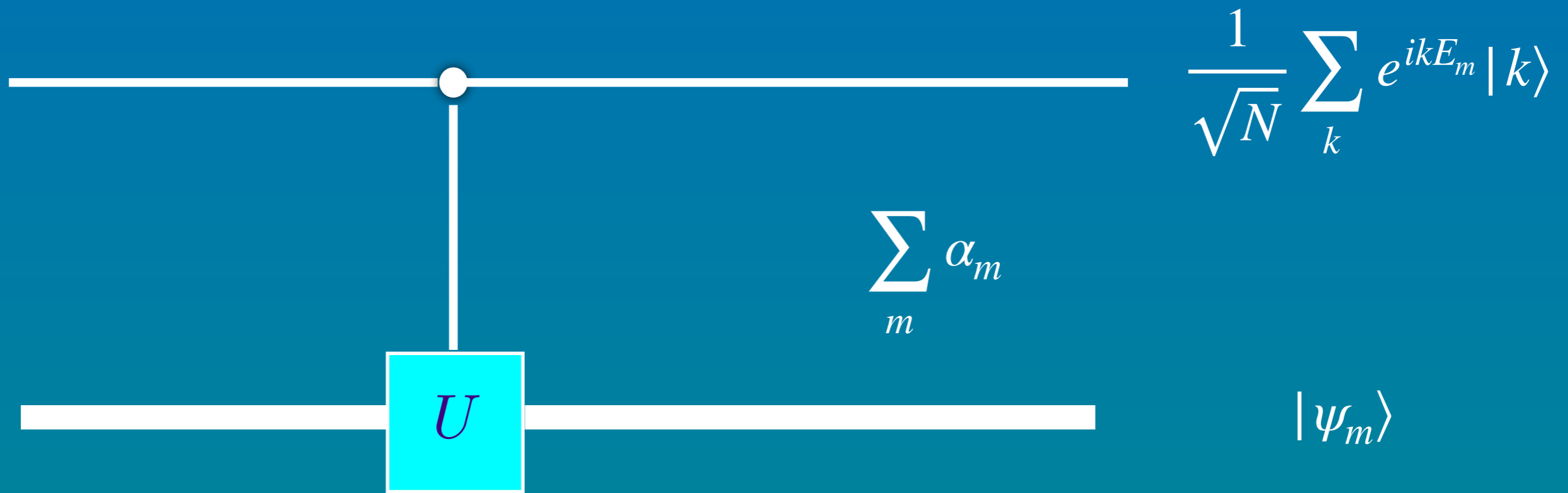

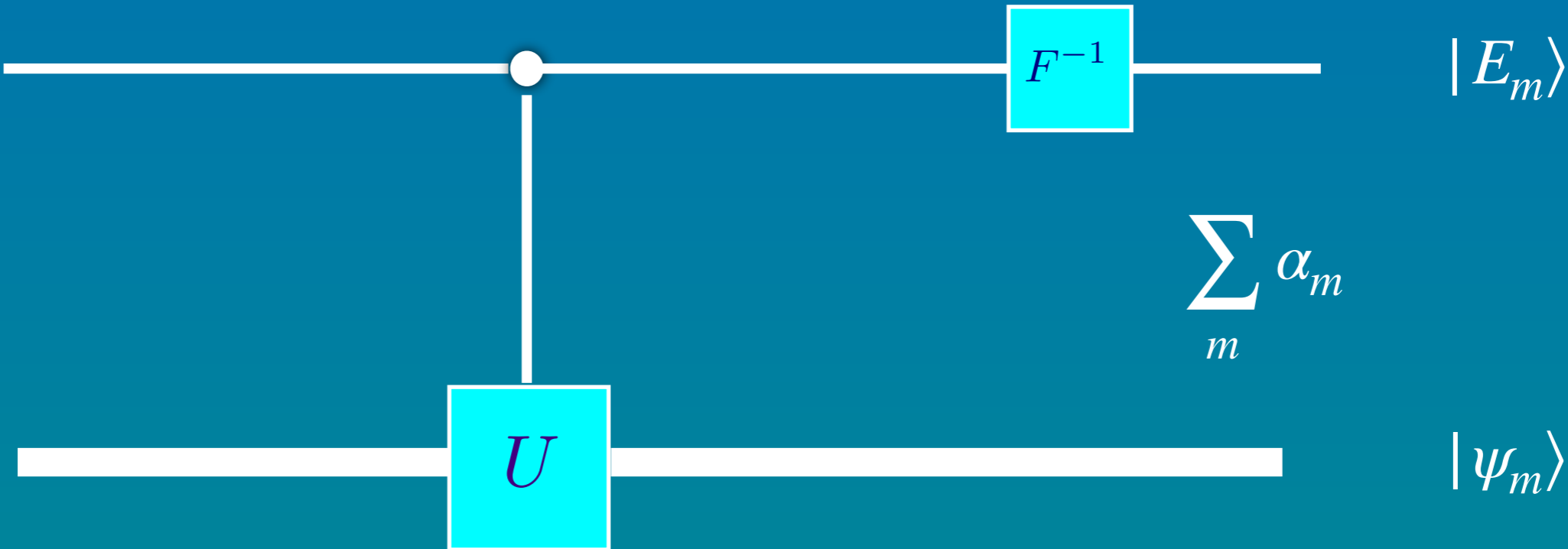

A2-Digital Simulation of spin systems

a spin in a magnetic field



$$H = -\mu B \sigma_z$$

$$U = e^{-i\lambda\sigma_z}$$

Two interacting spins



$$H = -JZ_1Z_2$$

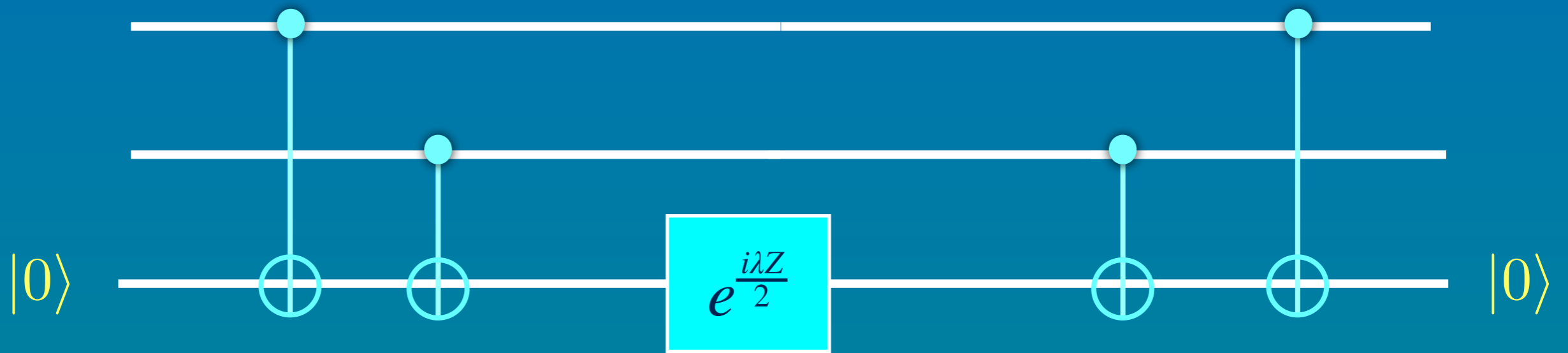

The clue $\longrightarrow m \oplus n = m + n - 2mn$

$$H = -JZ_1Z_2$$

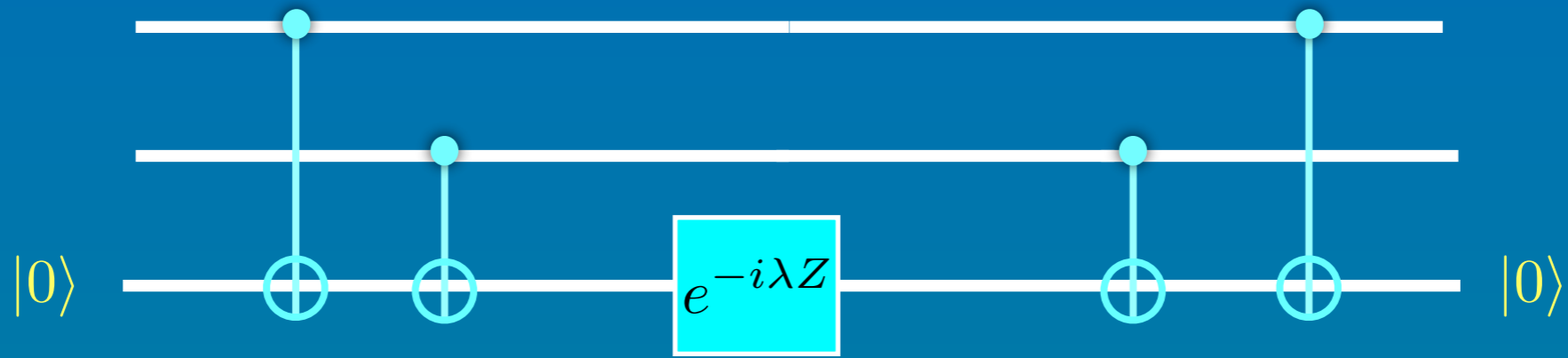

=

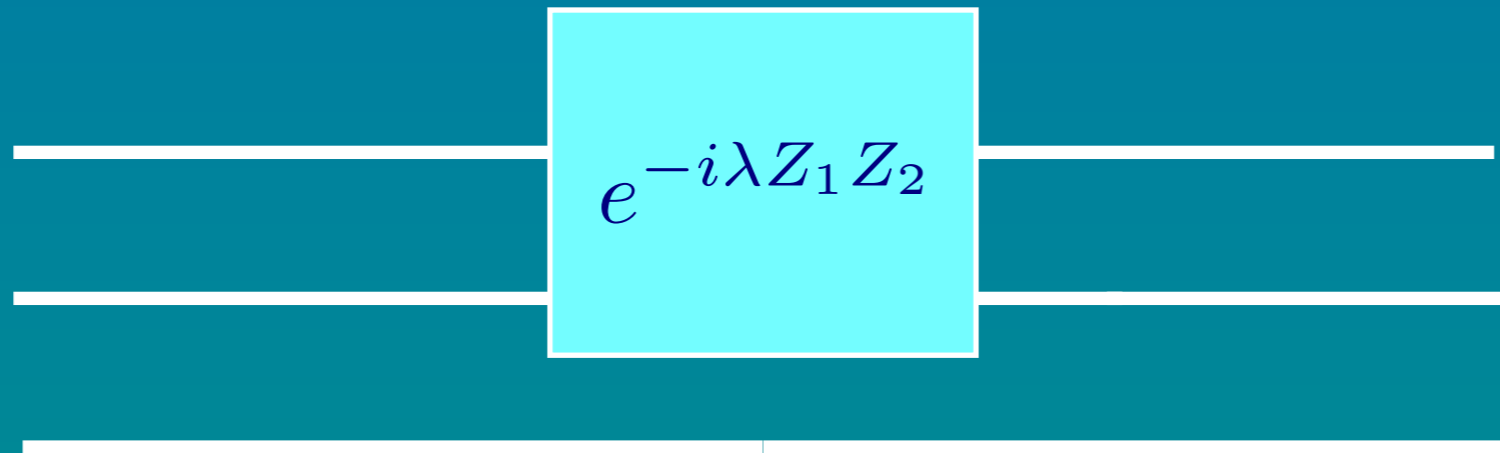

$$H = -JX_1X_2$$

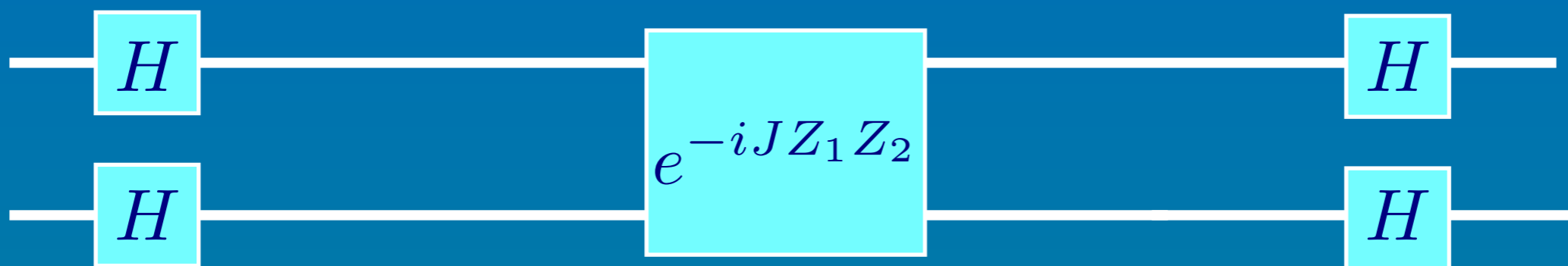

||

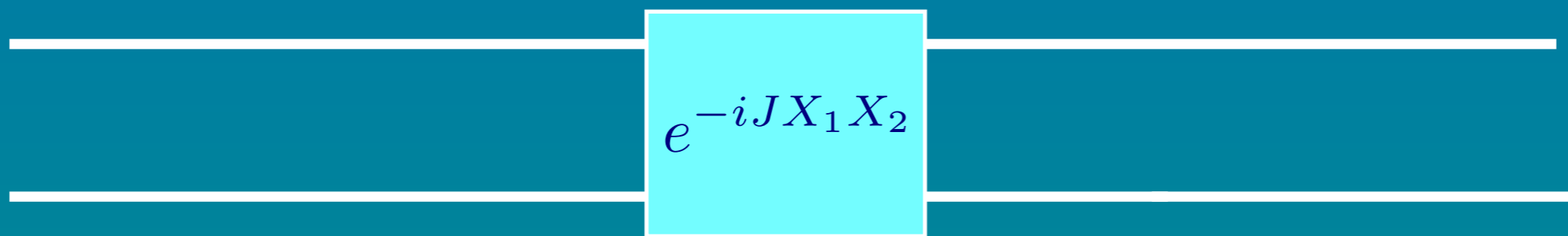

$$H = -JY_1Y_2$$

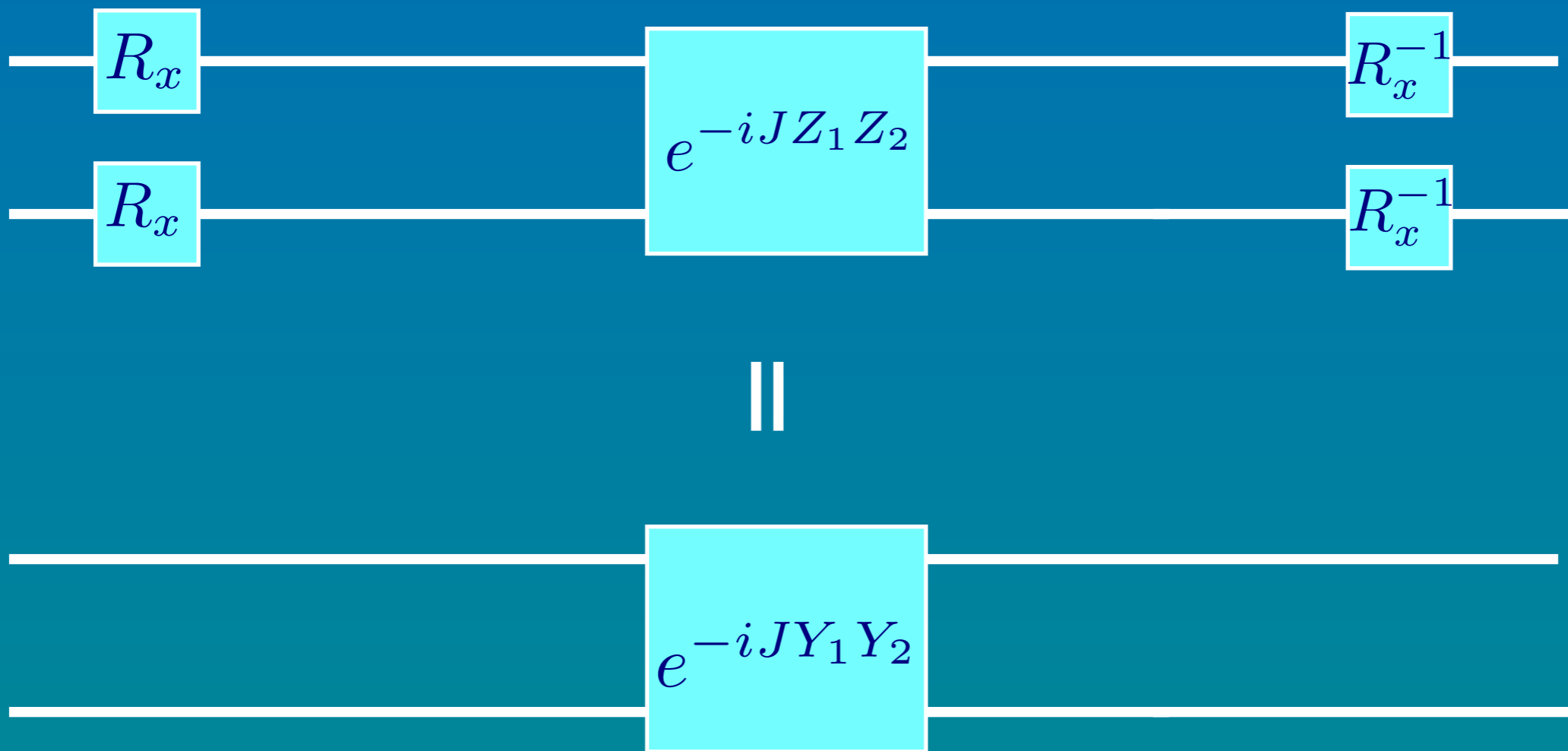

$$H = -JS_1 \cdot S_2$$

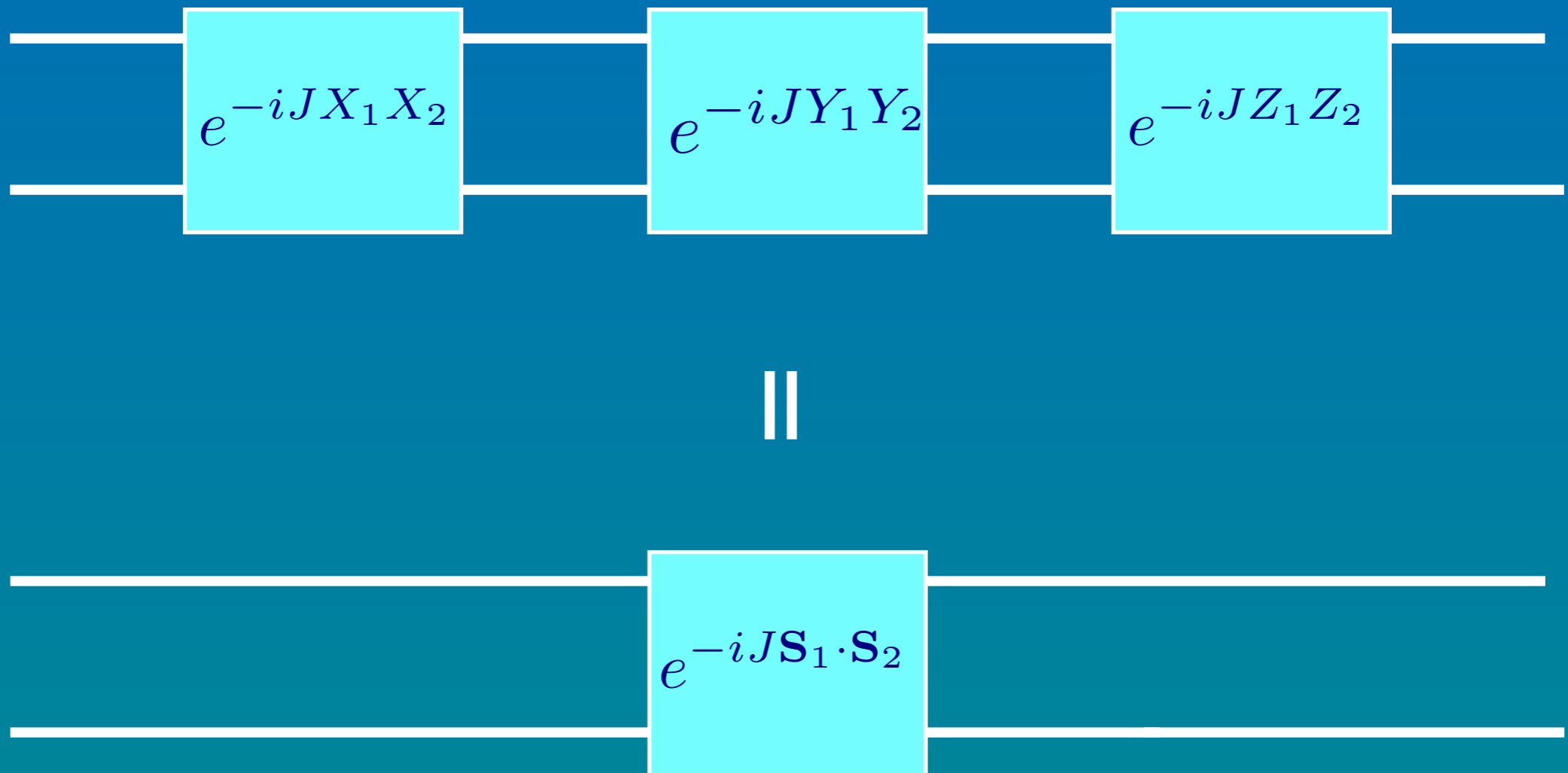

Three interacting spins and more!

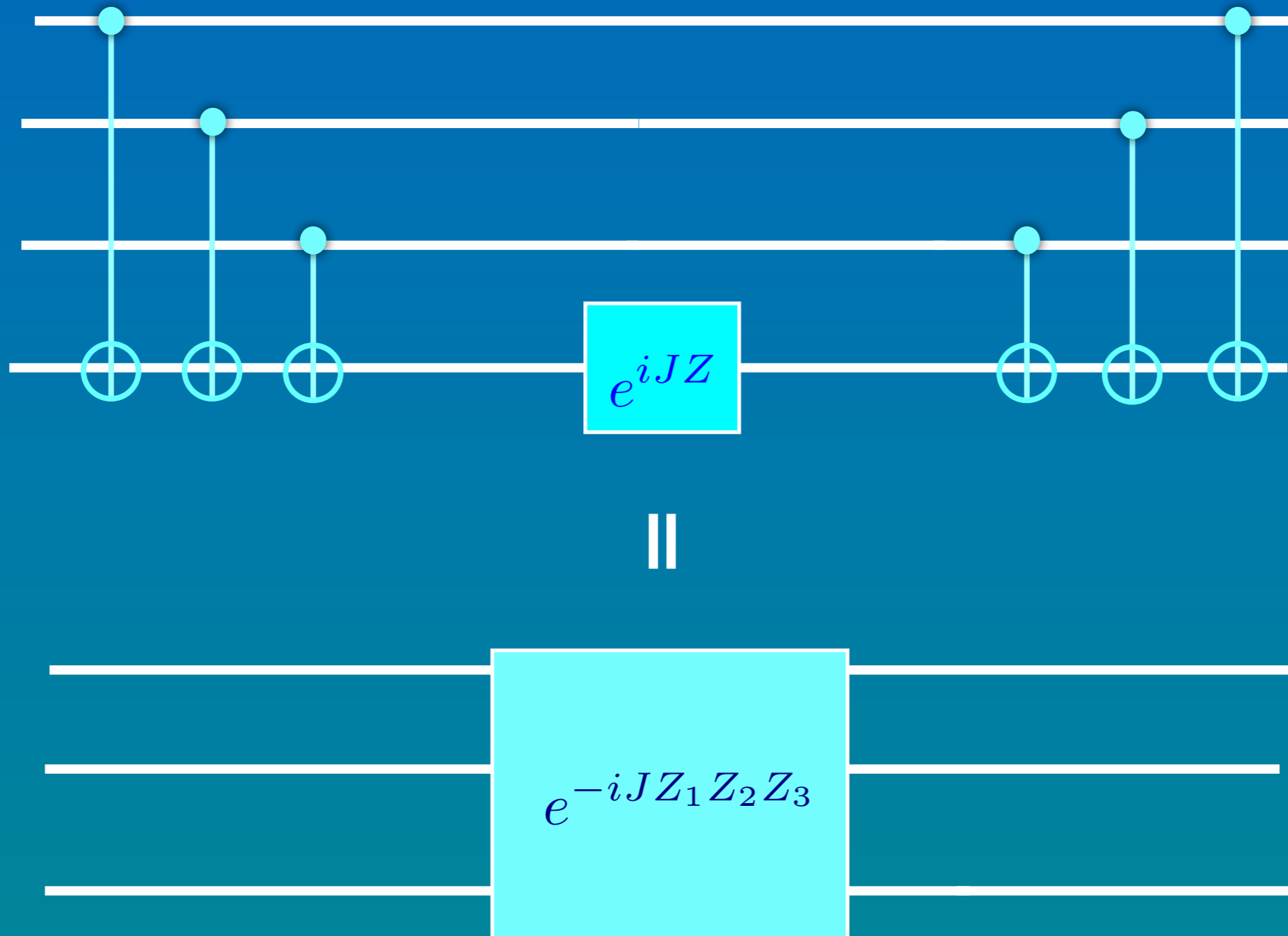

Why do we need these types of gates?

تجزیه هامیلتونی به جملاتی که با هم جابجا می شوند

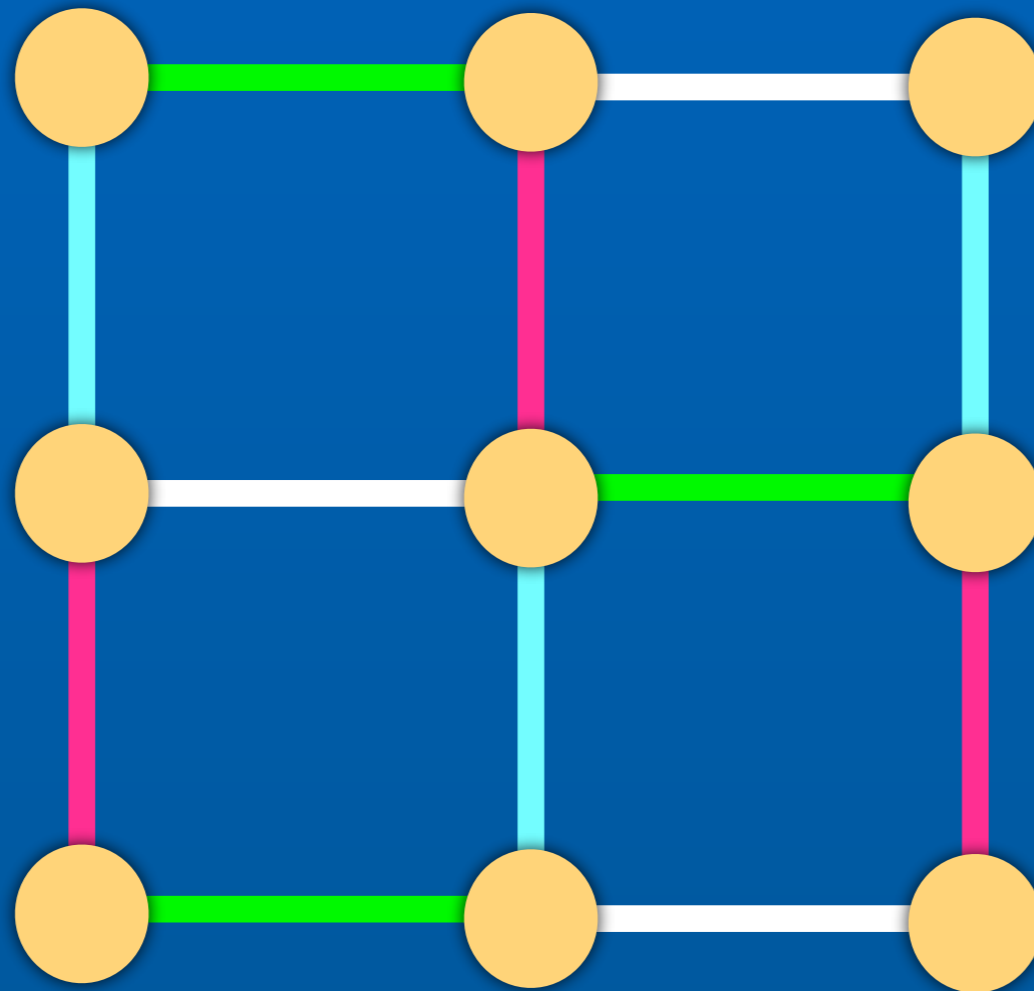

$$H = H_1 + H_2 + H_3 + H_4$$

Suzuki-Trotter Formula

$$e^A e^B = e^{A+B+\frac{1}{2}\{A,B\}+\dots}$$

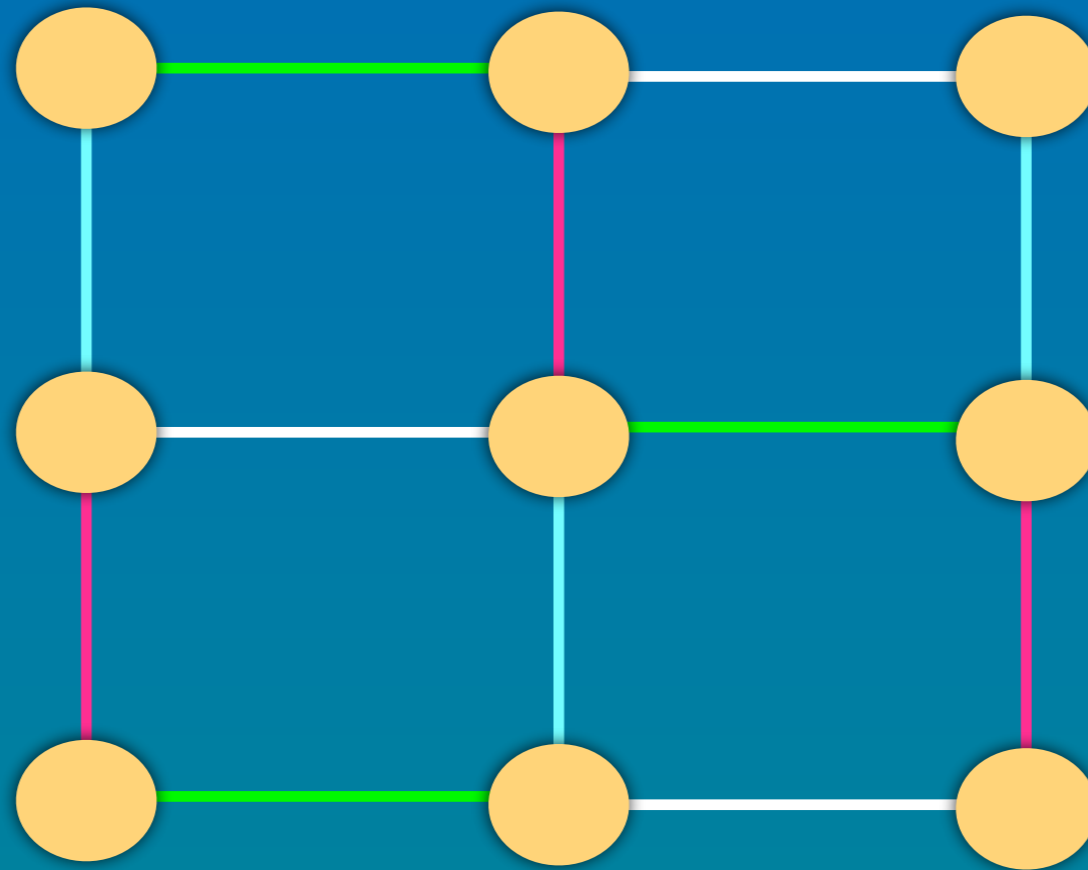

$$e^{H_1+H_2} = \left(e^{\frac{H_1}{N}} e^{\frac{H_2}{N}} \right)^N$$

c-Digital Simulation of Fermions

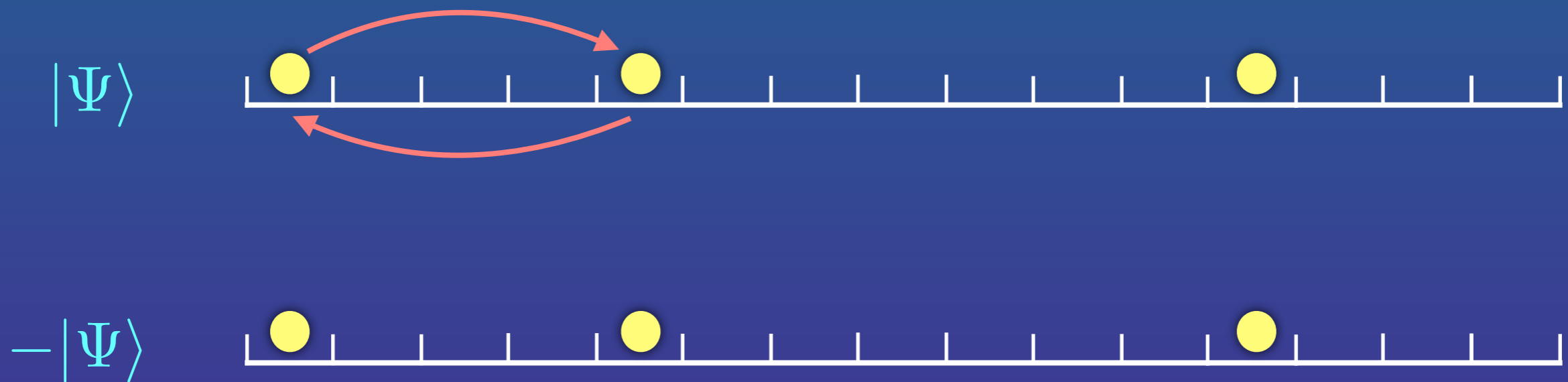

$$\{c_i, c_j\} = 0$$

$$\{c_i^\dagger, c_j^\dagger\} = 0$$

$$\{c_i, c_j^\dagger\} = \delta_{i,j}$$

Hubbard Model

$$H = -t \sum_{i,\sigma} c_{i,\sigma}^\dagger c_{i+1,\sigma} + c_{i+1,\sigma}^\dagger c_{i,\sigma} + U \sum_i n_{i,\uparrow} n_{i,\downarrow} \quad \sigma = \uparrow, \downarrow$$

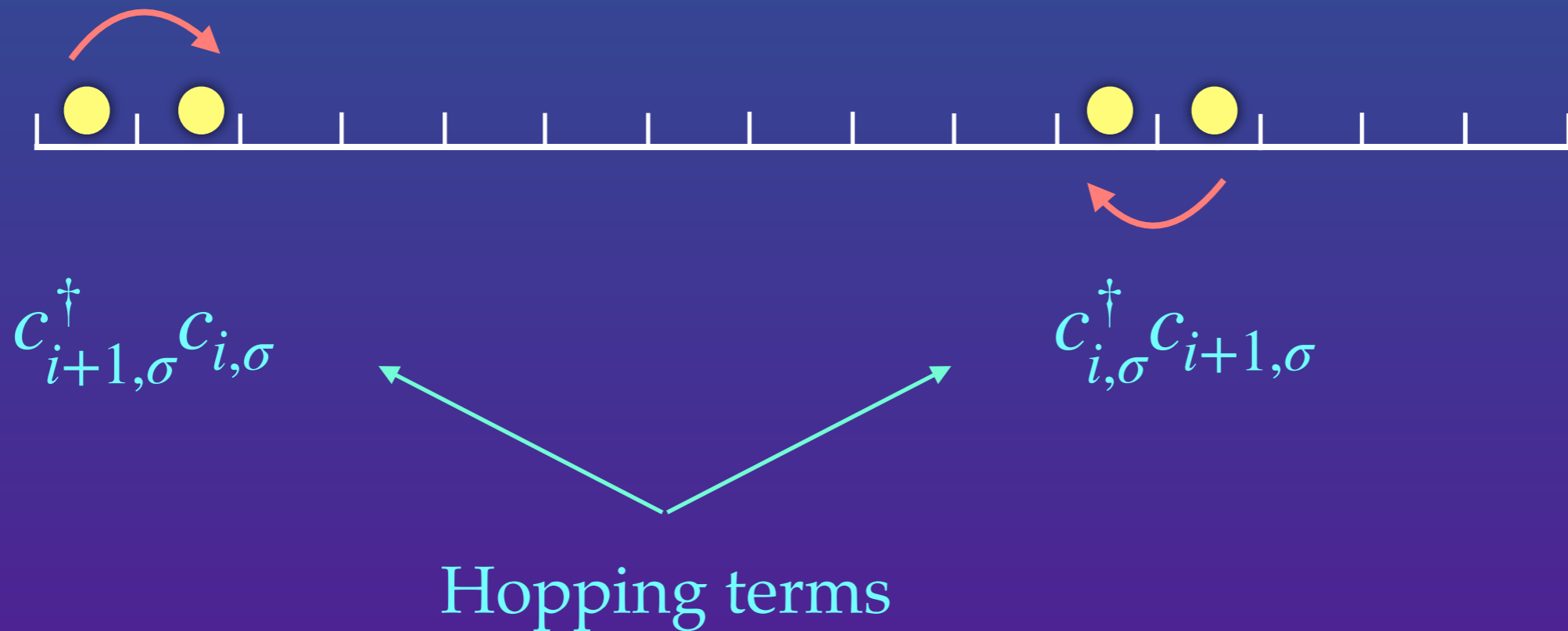

Jordan-Wigner Transformation

$$c_i = z_1 z_2 \cdots z_{i-1} \sigma_i^-$$

$$c_i^\dagger = z_1 z_2 \cdots z_{i-1} \sigma_i^+$$

$$c_i^\dagger |0\rangle$$

How to create a fermion?

$$|\Psi\rangle = c_{j_1}^\dagger c_{j_2}^\dagger \cdots c_{j_n}^\dagger |0\rangle$$

$$= e^{i\frac{\pi}{2}(c_{j_1} + c_{j_1}^\dagger)} \cdots e^{i\frac{\pi}{2}(c_{j_n} + c_{j_n}^\dagger)} |0\rangle$$

$$e^{i\frac{\pi}{2}(c_j + c_j^\dagger)} = e^{i\frac{\pi}{2} z_1 z_2 \cdots z_{j-1} \sigma_x}$$

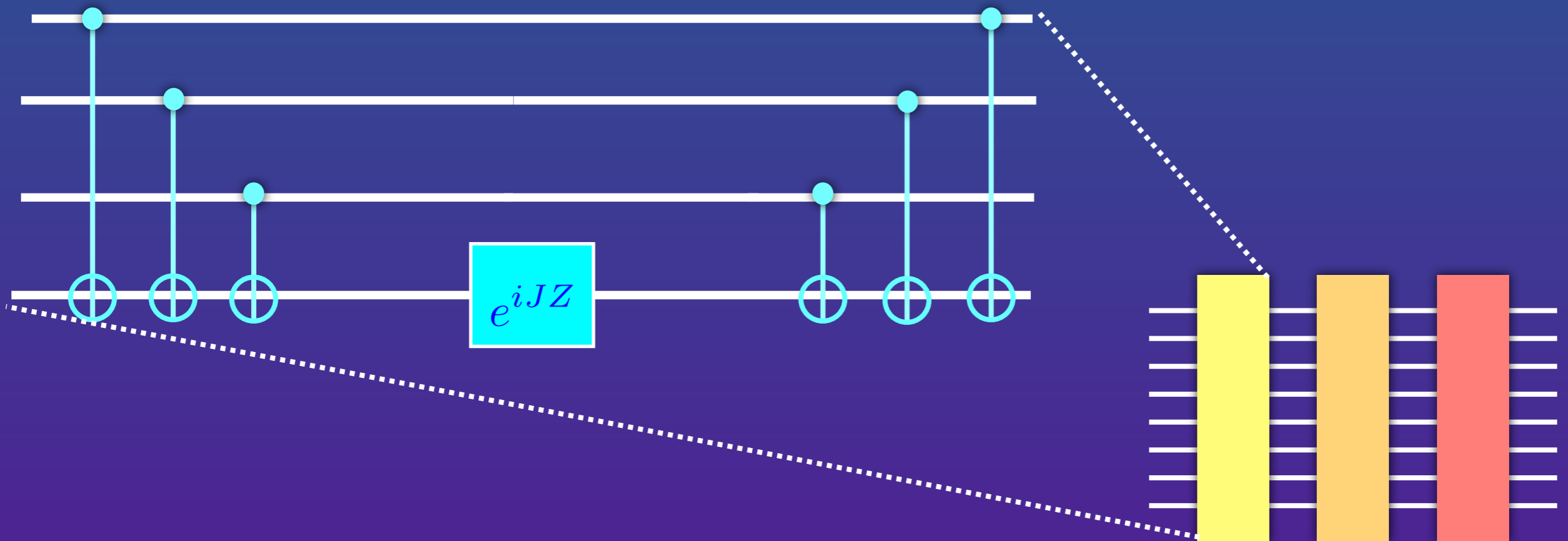

d-Digital Simulation of Bosons

Bose-Hubbard Model,...

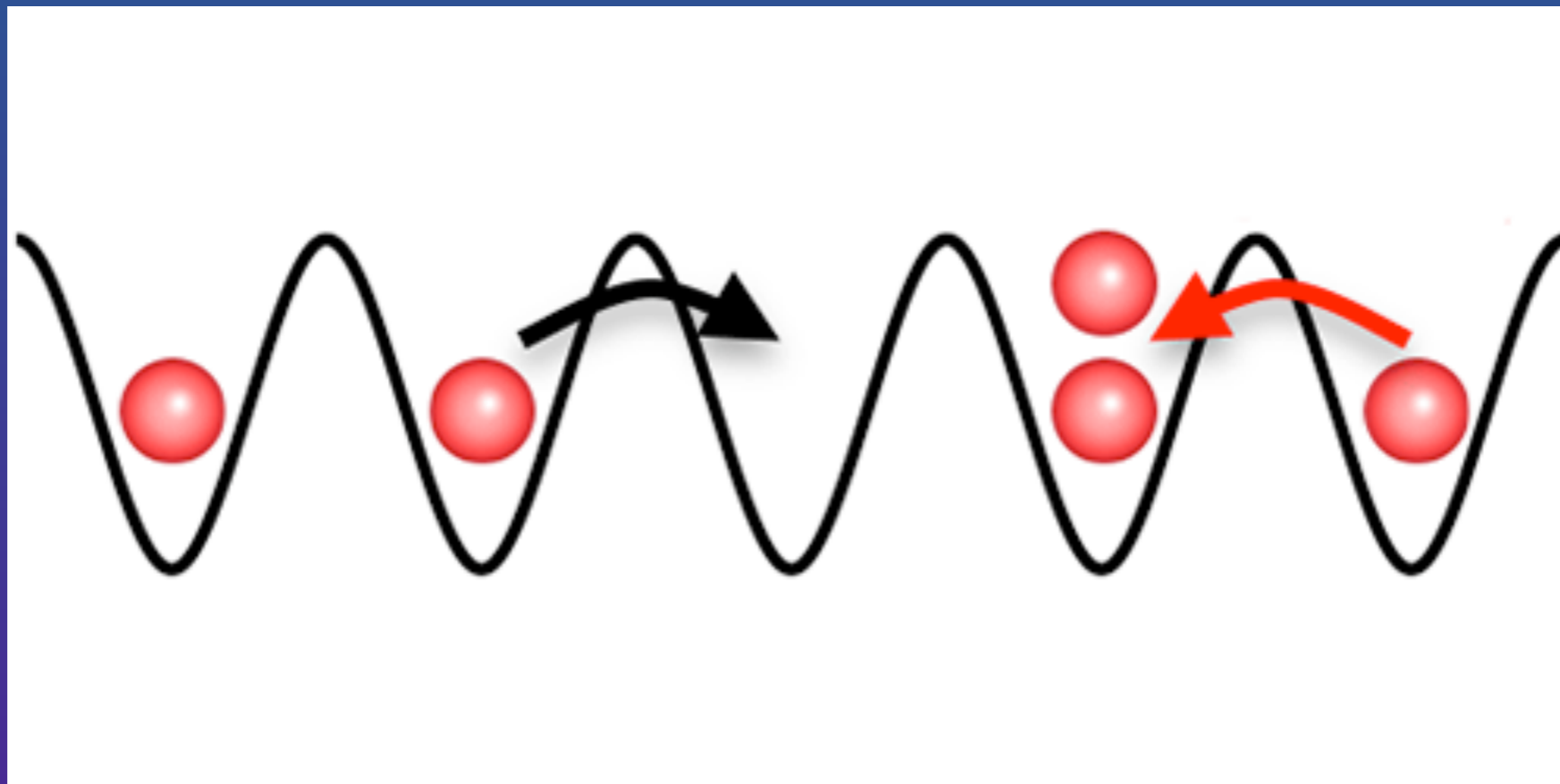

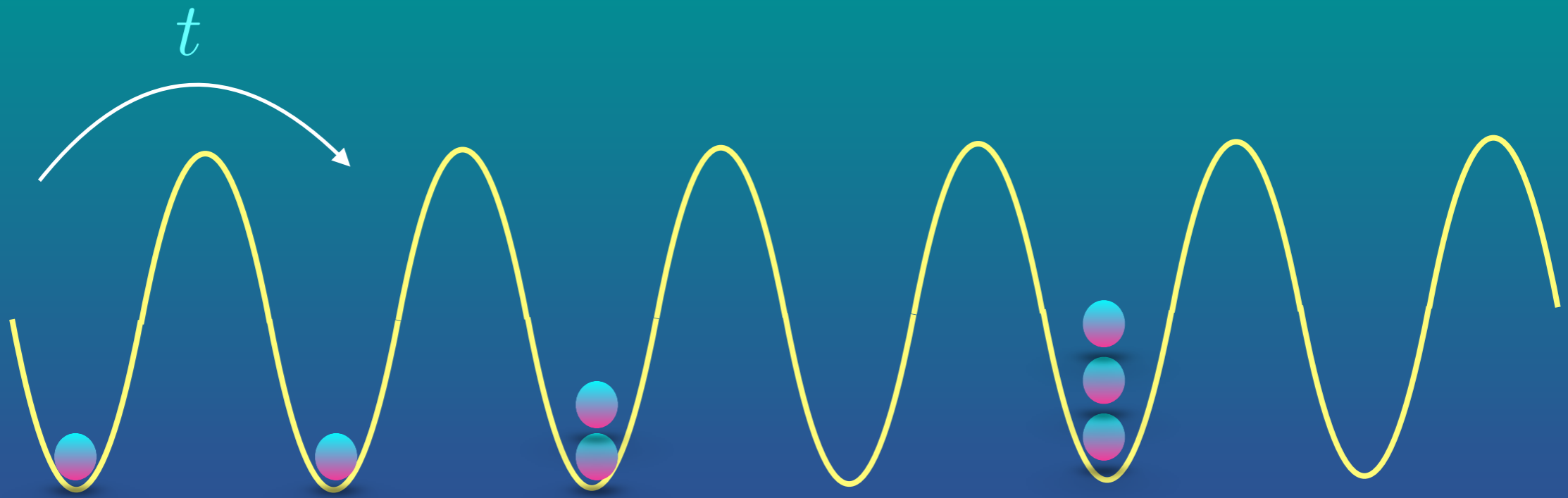

$$H = t \sum_{\langle i,j \rangle} b_i^\dagger b_j + \sum_i \epsilon_i n_i + \sum_i n_i (n_i - 1)$$

The Bose-Hubbard Hamiltonian



$$|0\rangle_b = |1, 0, 0, \dots 0\rangle$$

$$|1\rangle_b = |0, 1, 0, \dots 0\rangle$$

$$|2\rangle_b = |0, 0, 1, \dots 0\rangle$$

.....

$$|N\rangle_b = |0, 0, 0, \dots 1\rangle$$

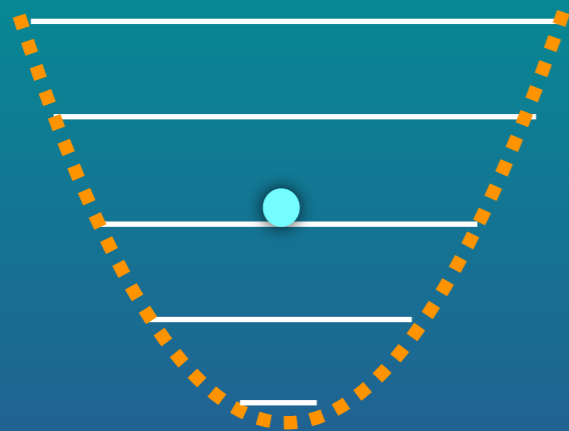

$|2\rangle$

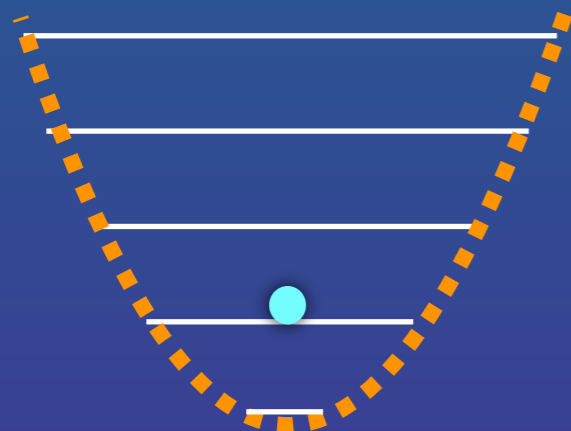

$|1\rangle$

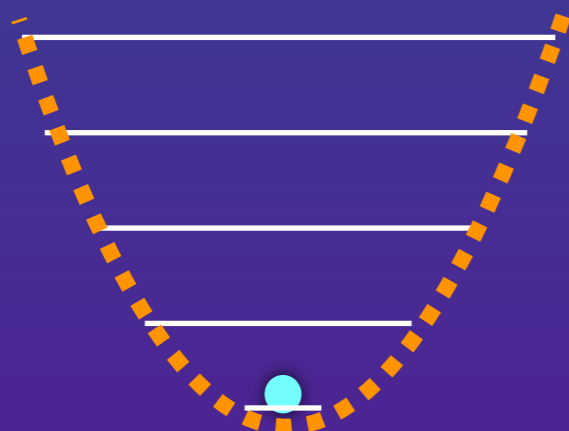

$|0\rangle$

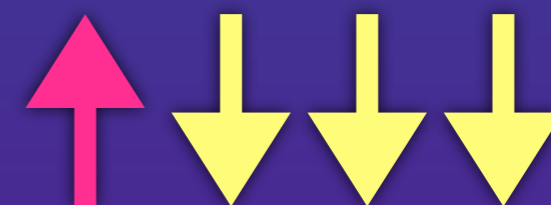

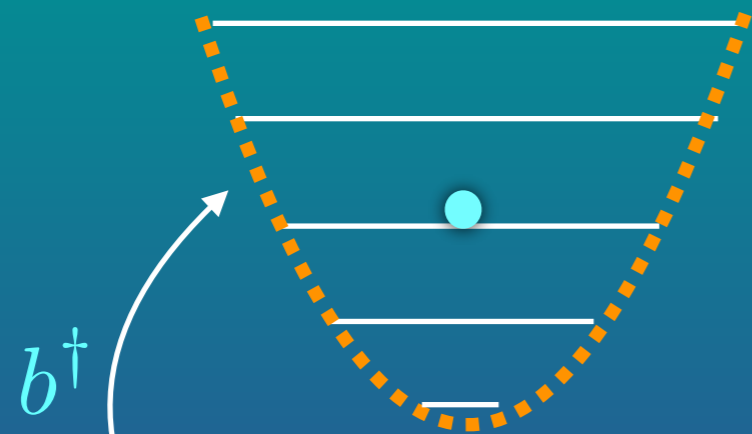

$$\sqrt{2} \sigma_1^+ \sigma_2^-$$

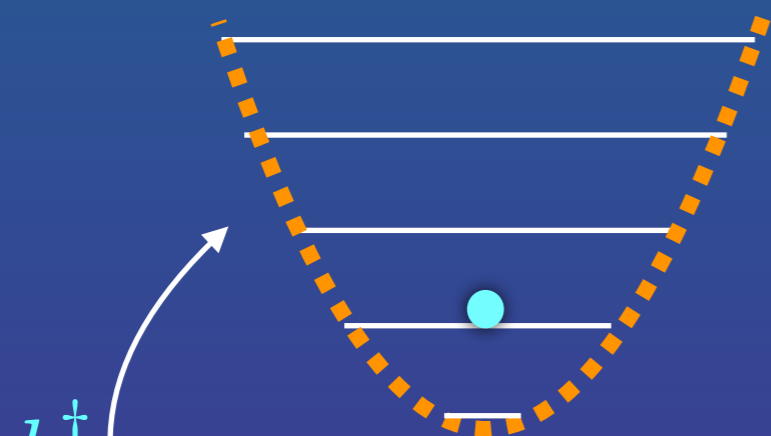

$$\sigma_0^+ \sigma_1^-$$

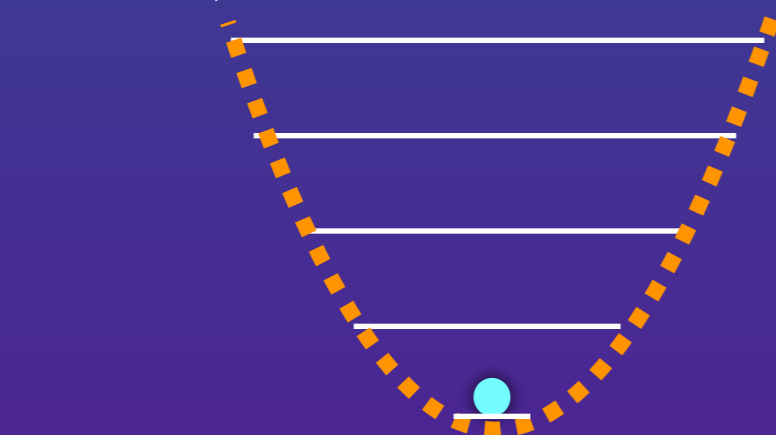

$$b^\dagger = \sum_{n=0}^{N_p-1} \sqrt{n+1} \sigma_n^+ \sigma_{n+1}^-$$

How to simulate the number operator?

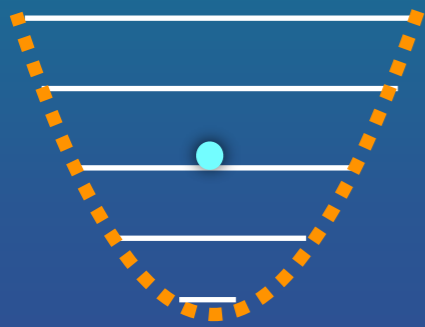

$|2\rangle$



$$\hat{n} |2\rangle = 2 |2\rangle$$

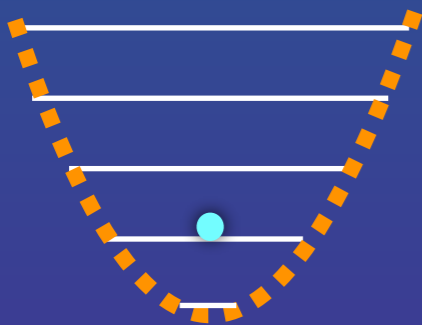

$|1\rangle$



$$\hat{n} |1\rangle = |1\rangle$$

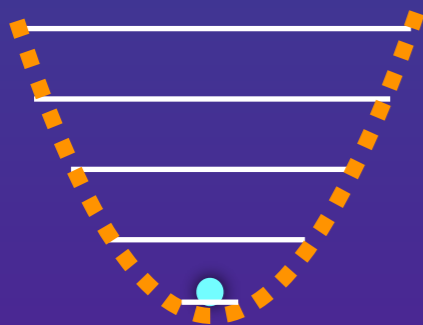

$|0\rangle$

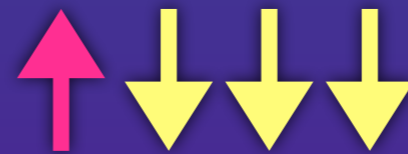

$$\hat{n} |0\rangle = 0$$

How to simulate the number operator?

$$Z|\downarrow\rangle = -|\downarrow\rangle$$

$$Z|\uparrow\rangle = |\uparrow\rangle$$

$$\hat{n} = \sum_{k=0}^l k \frac{1 + Z_k}{2}$$

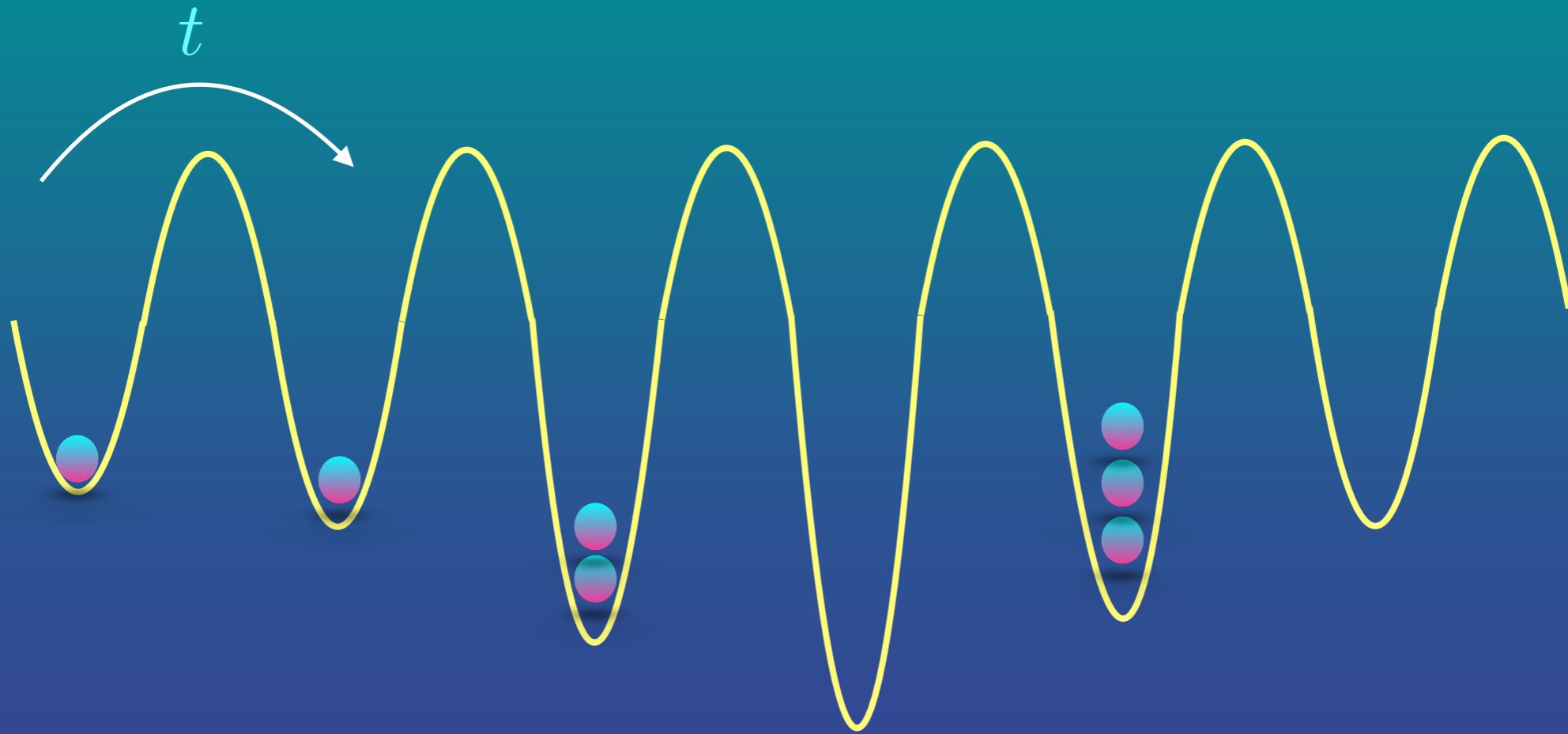

$$H = \sum_{\langle i,j \rangle} b_i^\dagger b_j + \sum_i \epsilon_i n_i + \sum_i n_i(n_i - 1)$$

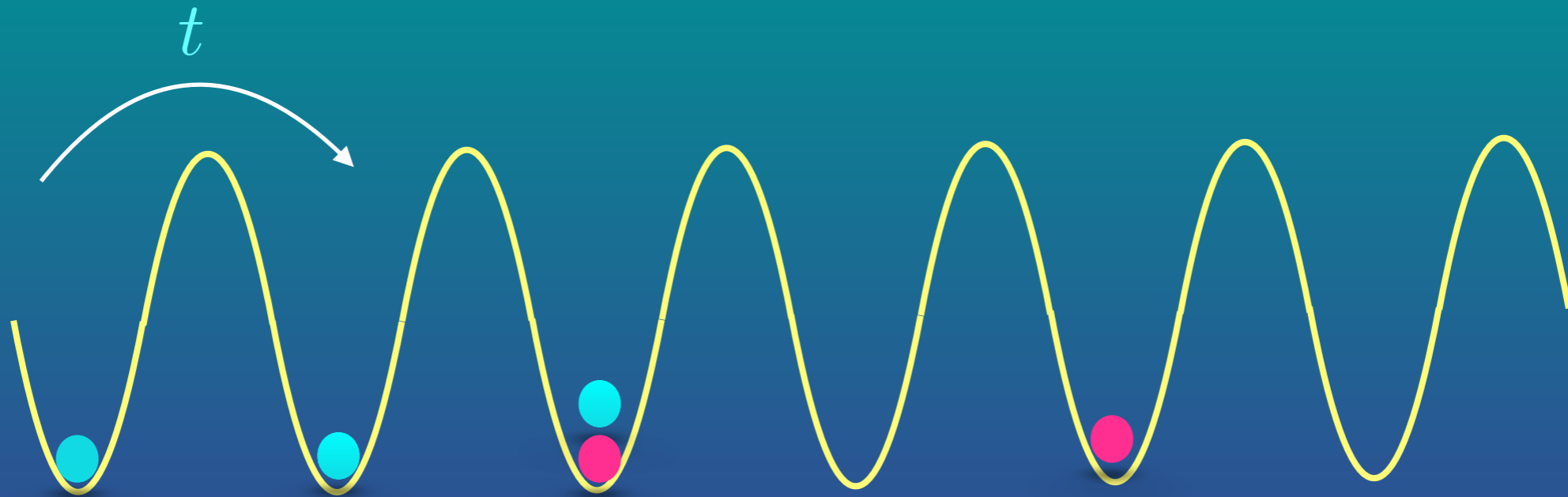

$$H = t \sum_{\langle i,j,\sigma \rangle} c_{i,\sigma}^\dagger c_{j,\sigma} + \sum_i \epsilon_{i,\sigma} n_{i,\sigma} + U \sum_{i,\sigma} n_{i,\sigma} n_{i,\bar{\sigma}}$$

e-Quantum simulation of field theories

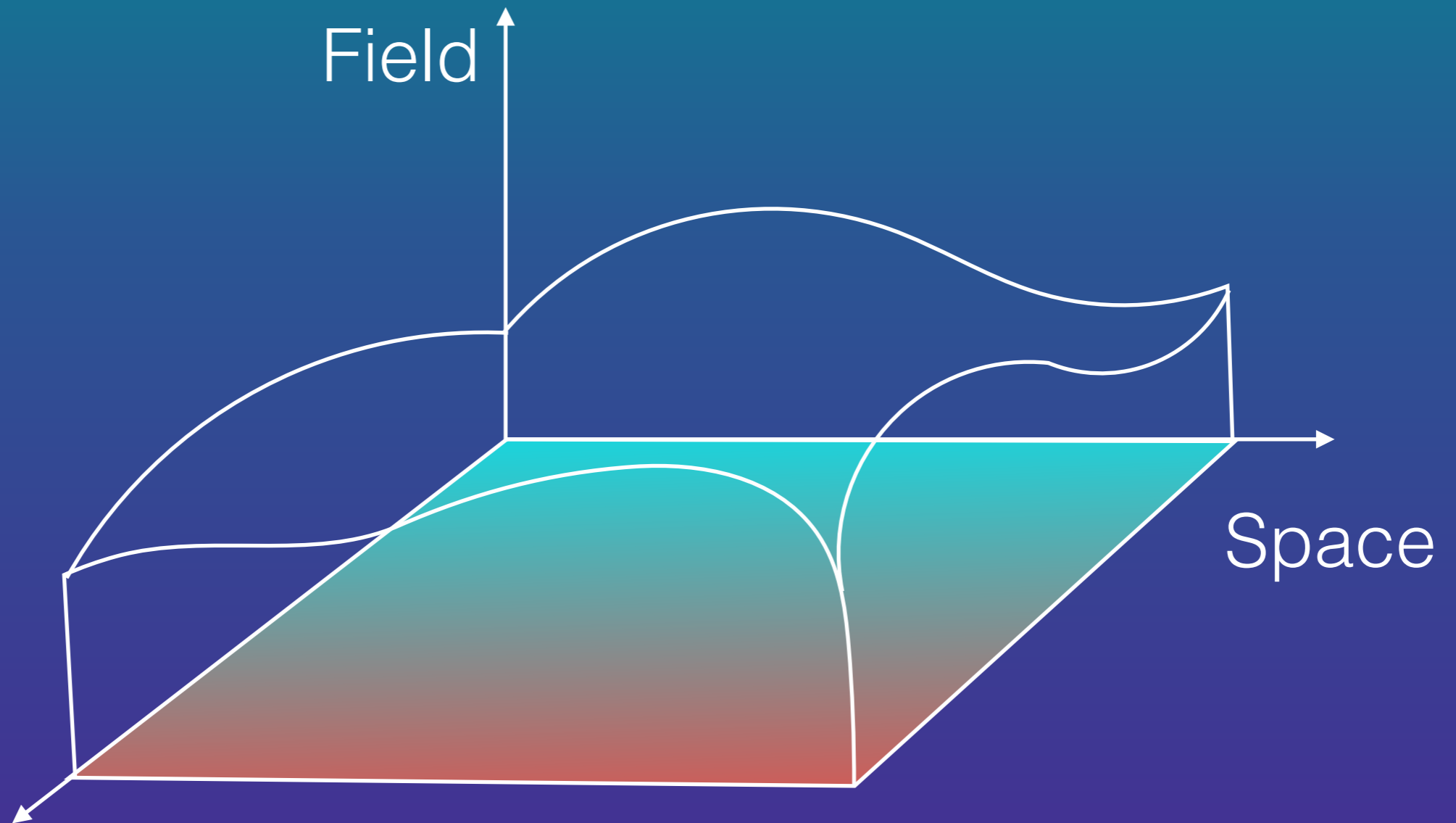

$$H = \int d^D x \left[\frac{1}{2} \pi(x)^2 + \frac{1}{2} (\nabla \phi)^2(x) + \frac{1}{2} m^2 \phi(x)^2 + \frac{\lambda}{4} \phi(x)^4 \right]$$

Discretize the space

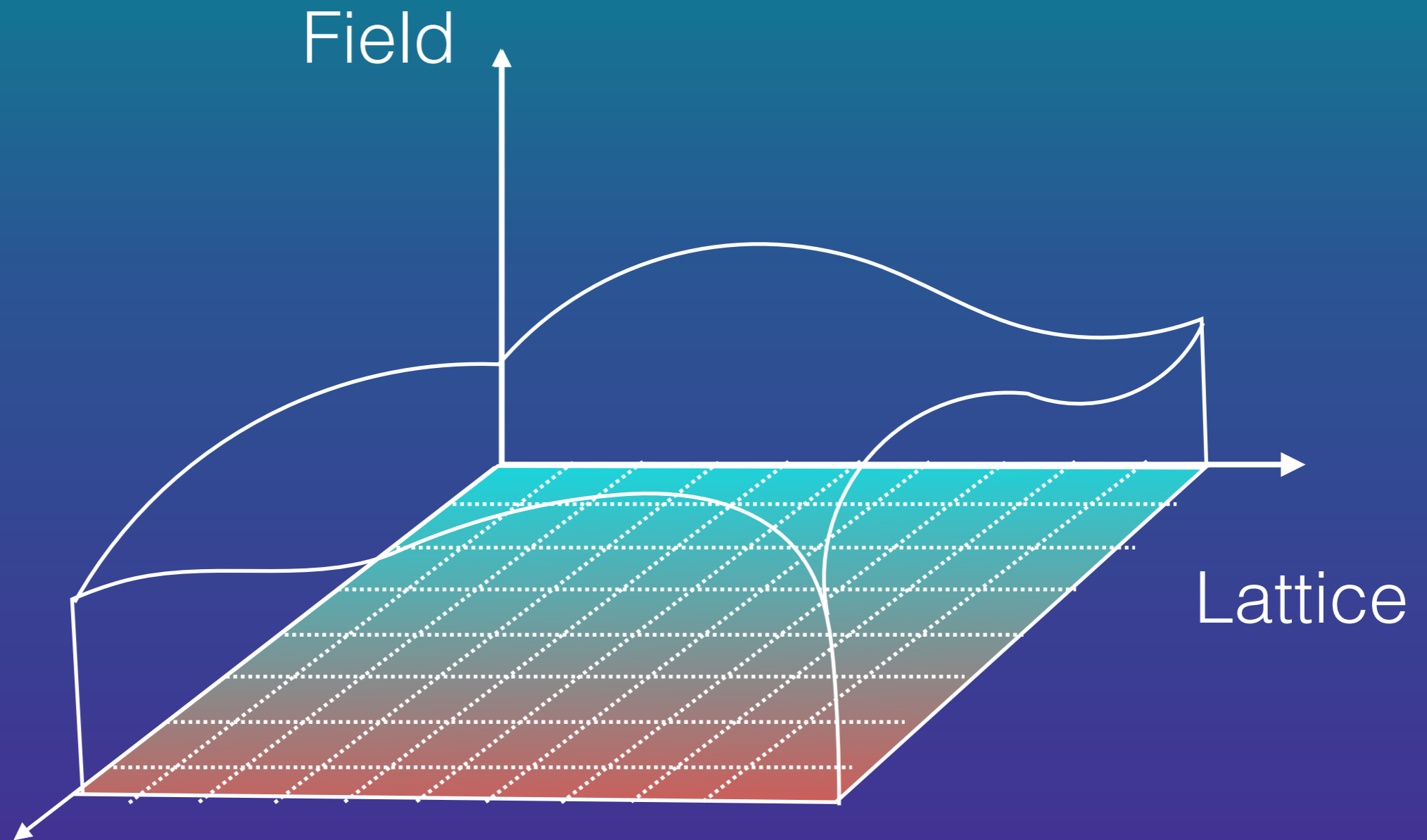

$$H = a^D \sum_{\mathbf{n}} \left[\frac{1}{2} \pi(\mathbf{n})^2 + \frac{1}{2} (\nabla \phi)^2(\mathbf{n}) + \frac{1}{2} m^2 \phi(\mathbf{n})^2 + \frac{\lambda}{4} \phi(\mathbf{n})^4 \right]$$

Discretize the field

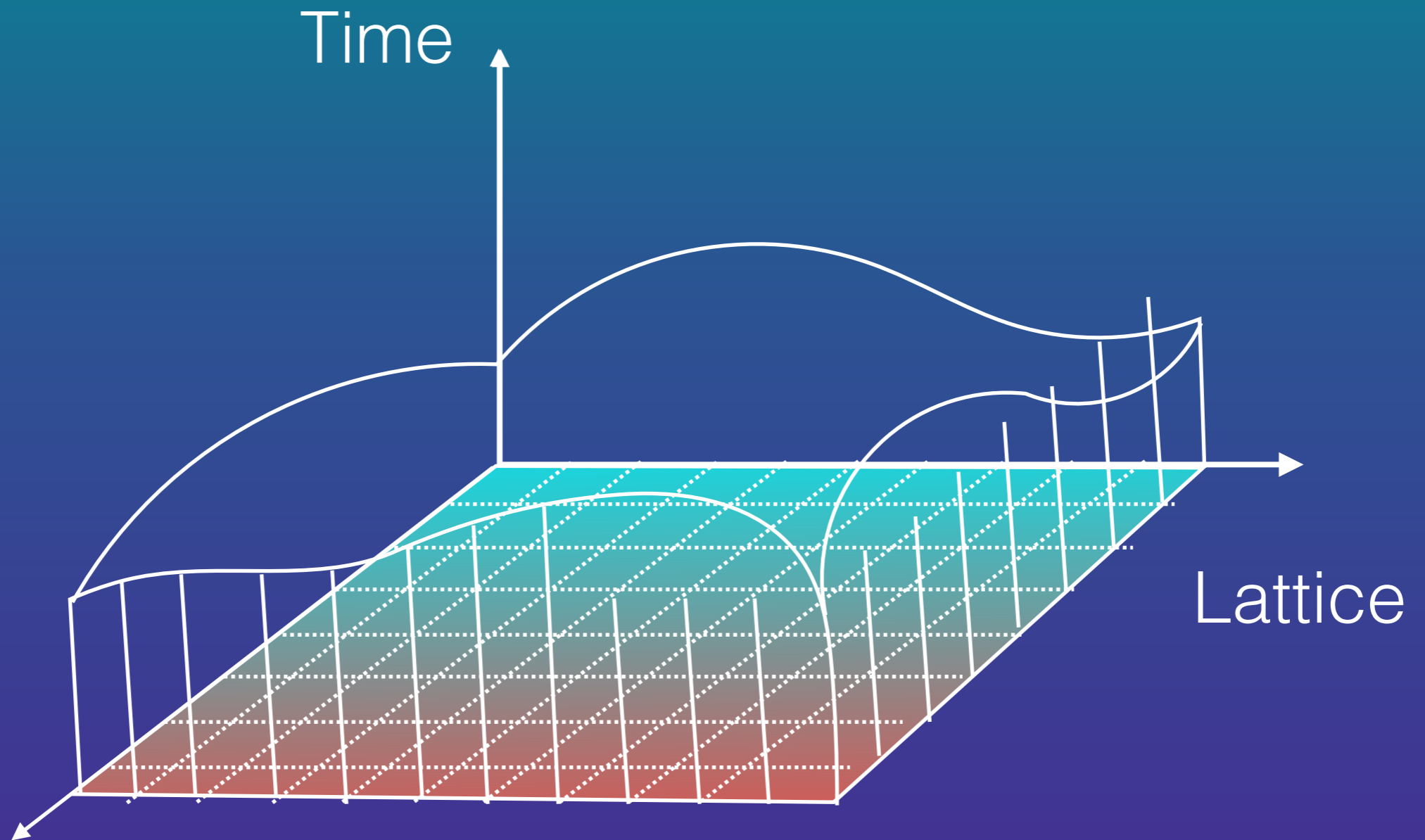

$$H = a^D \sum_{\mathbf{n}} \left[\frac{1}{2} \pi(\mathbf{n})^2 + \frac{1}{2} (\nabla \phi)^2(\mathbf{n}) + \frac{1}{2} m^2 \phi(\mathbf{n})^2 + \frac{\lambda}{4} \phi(\mathbf{n})^4 \right]$$

Scattering

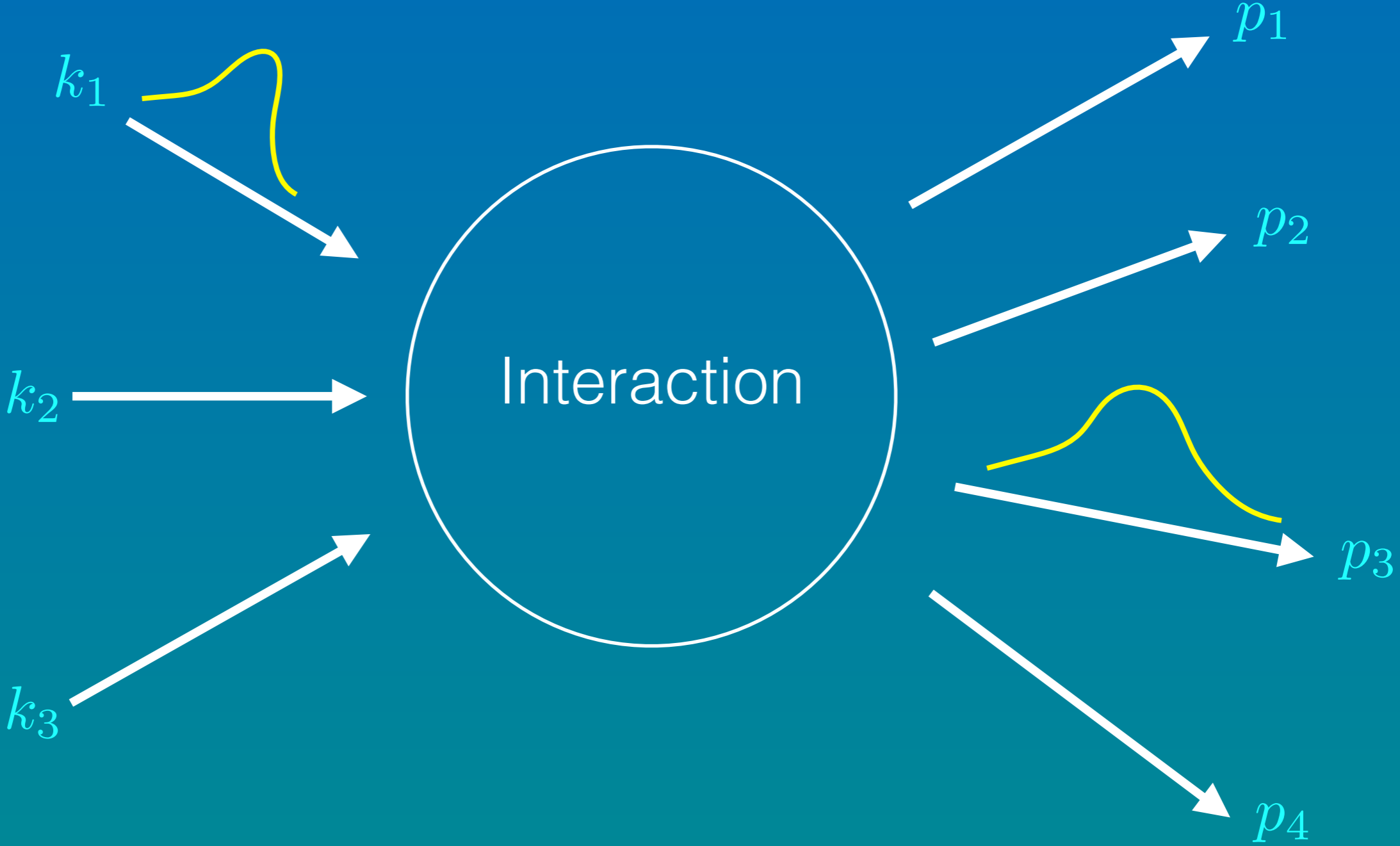

B-Analog Quantum Simulation

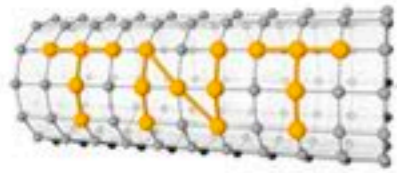

Analogue quantum simulation

Such model Hamiltonian are now accurately realisable with cold atoms:

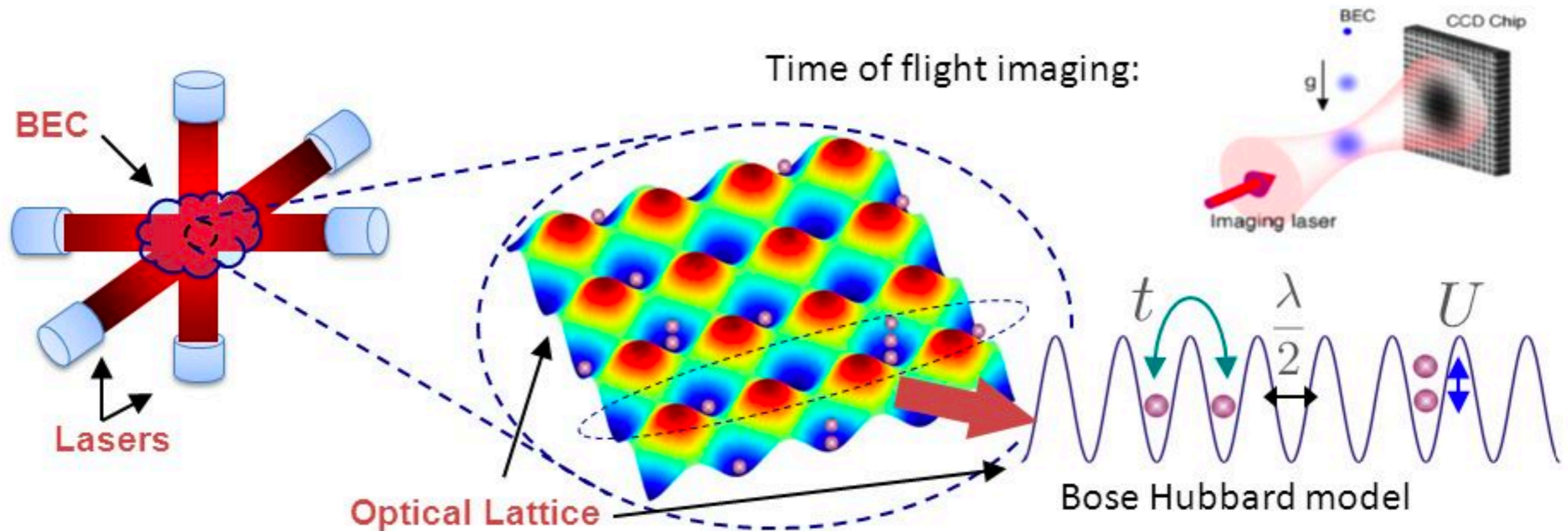

Superfluid : $t \gg U$

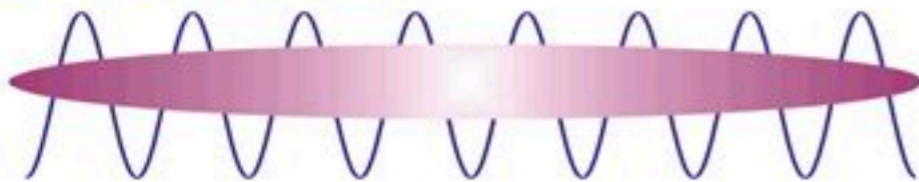

quantum phase transition

Mott-Insulator : $U \gg t$

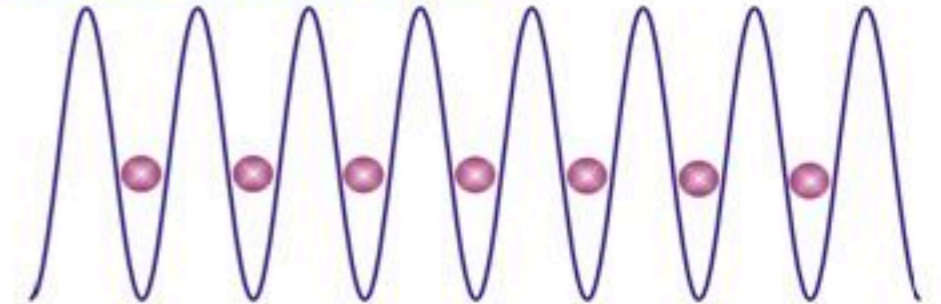

Fermionic Systems

Electron Gas, Hubbard Model, Superconductivity...

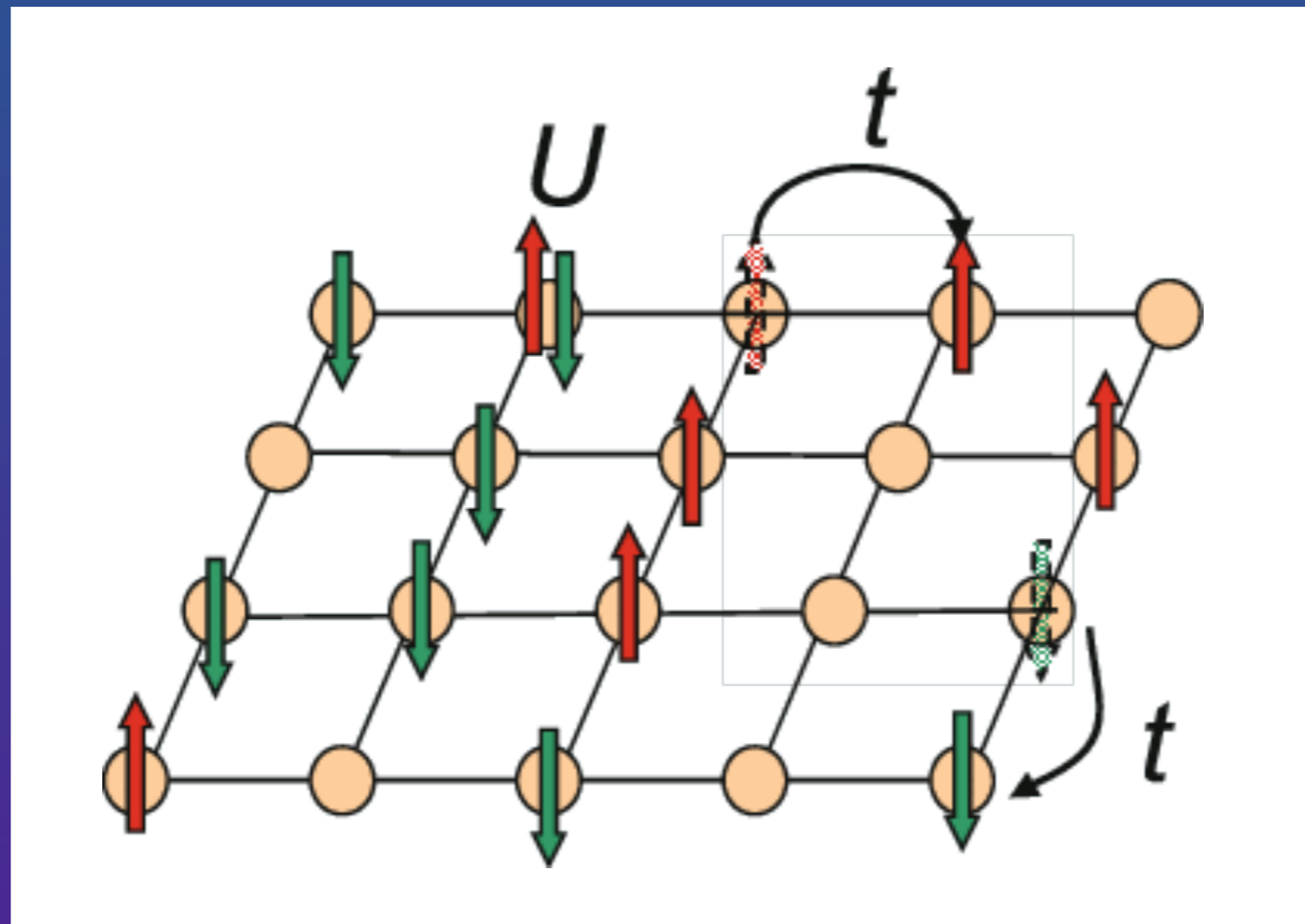

Chemistry and material science



ANNUAL REVIEWS **Further**

Click here for quick links to Annual Reviews content online, including:

- Other articles in this volume
- Top cited articles
- Top downloaded articles
- Our comprehensive search

Simulating Chemistry Using Quantum Computers

Ivan Kassal,* James D. Whitfield,*
Alejandro Perdomo-Ortiz, Man-Hong Yung,
and Alán Aspuru-Guzik

Department of Chemistry and Chemical Biology, Harvard University, Cambridge, Massachusetts 02138; email: aspuru@chemistry.harvard.edu

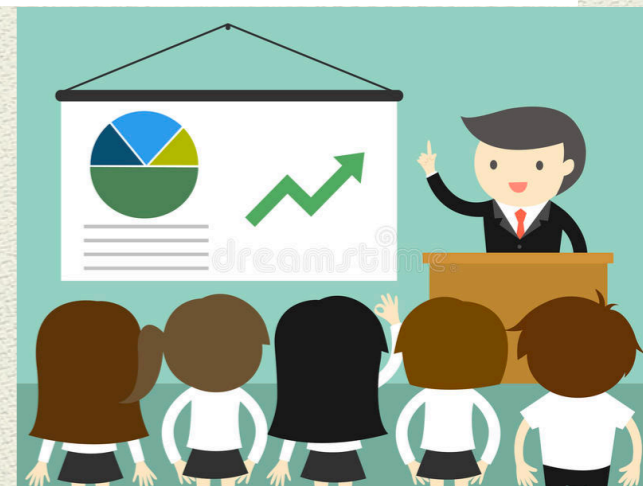

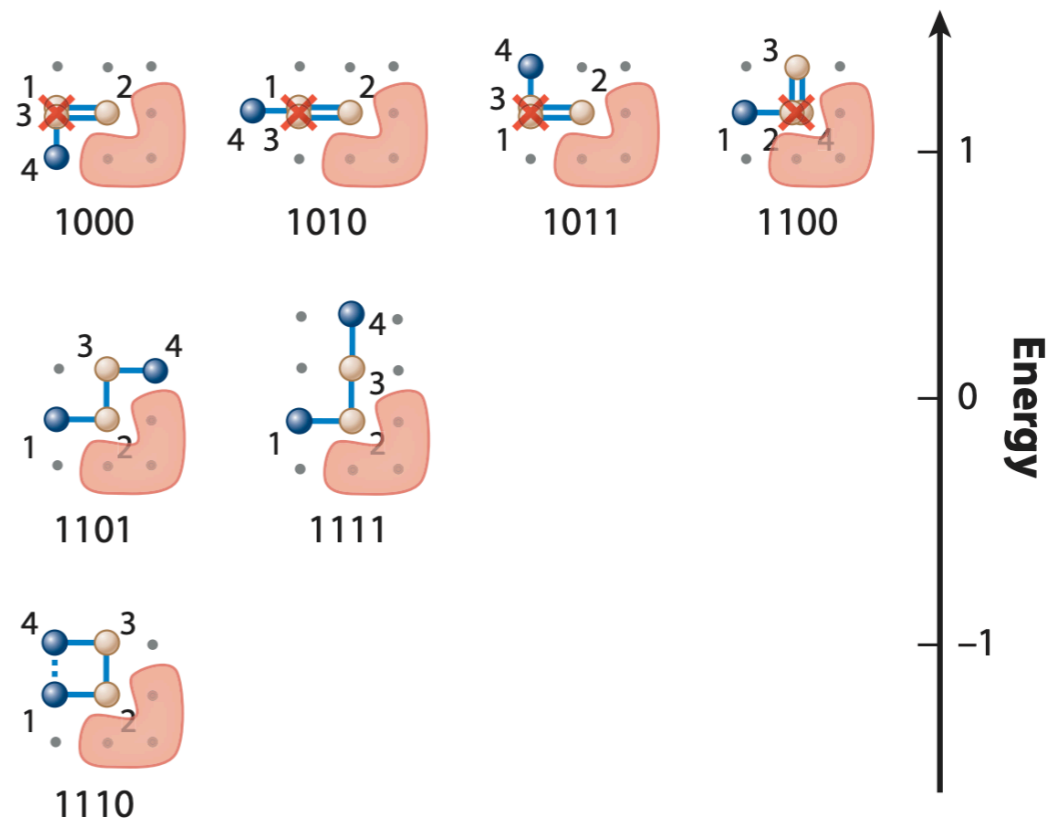
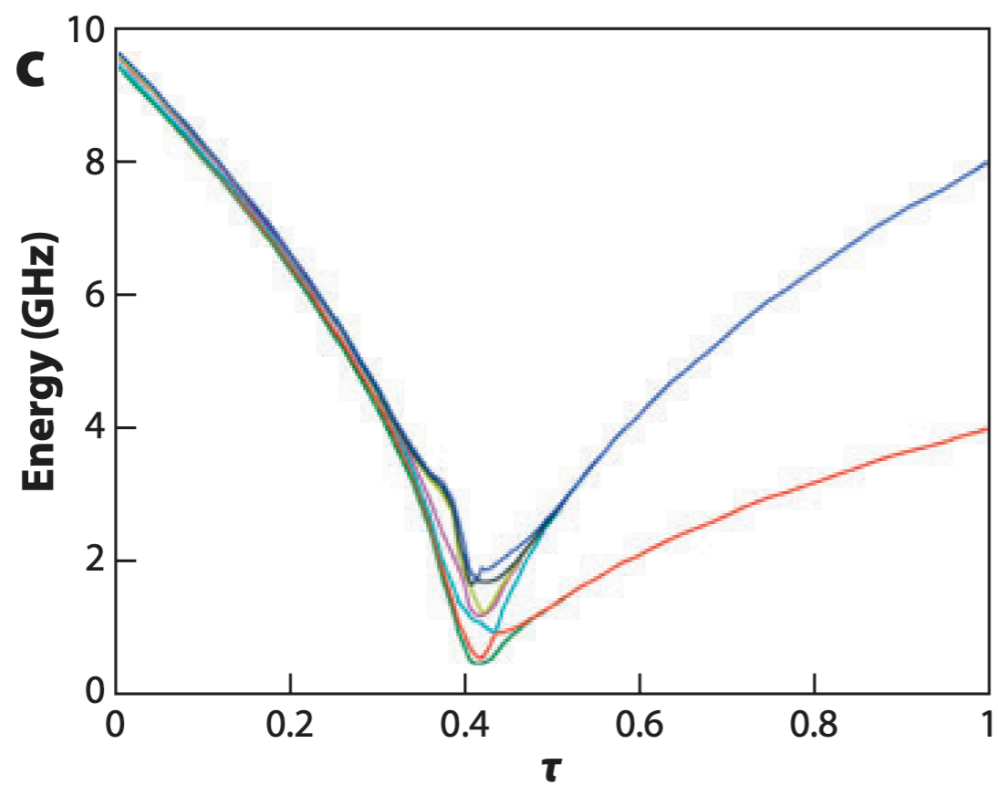
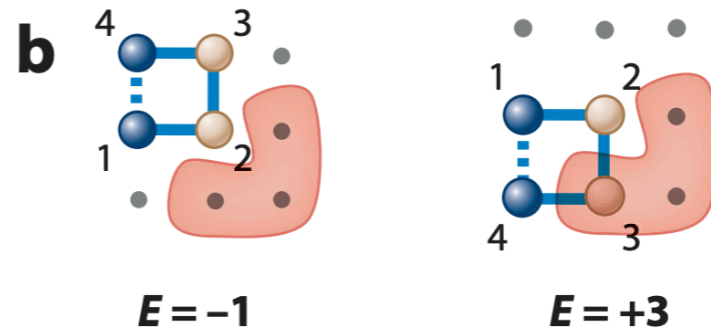
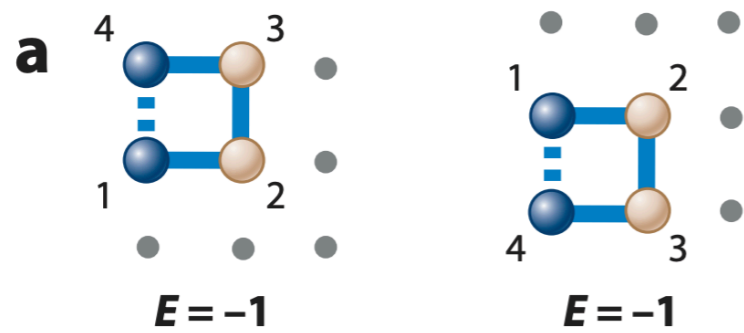

Opportunities in quantum simulation

◆ Impact on the society

Chemistry, Materials, Energy production,
agriculture, sustainability of our planet

A- The problem should be so hard to be solvable
only by quantum computers,

B- It should be of real scientific value with application

Difficulties in quantum simulation

Currently, simulating ground states of materials by classical computers is progressing fast for two reasons:

A- Faster computers,

B- Better algorithms

Difficulties in quantum simulation

The states of most materials is not highly entangled, so the quantum advantage for these materials is not exponential, but polynomial (147).

Moreover, these methods are heuristic and not rigorous, since if we want accurate results in an efficient way, the initial state should have a high overlap with the target state, which is a difficult problem.

A window in quantum simulation

Exponential speed up is expected in dynamics, when an initial state evolves to a highly entangled state, i.e. scattering in field theory (148).